



[www.hy-lok.com](http://www.hy-lok.com)

Catalog No. H - 230TF  
May 2016

# 24° Tube Fittings - DIN 2353 & ISO 8434 -1

## with Ball & Non Return Valves



**HY-LOK CORPORATION**

©1998, 2000, 2002, 2007, 2010, 2011, 2013, 2016 HY-LOK CORPORATION All rights reserved

## Features

- **Pressure** range up to 800 bar at 120°C
- **Constructive** design of the cutting-geometry.
- **Less effort.**
- **Force-increase** is perceptible.
- **Secure holding**-function is guaranteed.
- **Materials** are Stainless steel, Carbon steel and Brass.

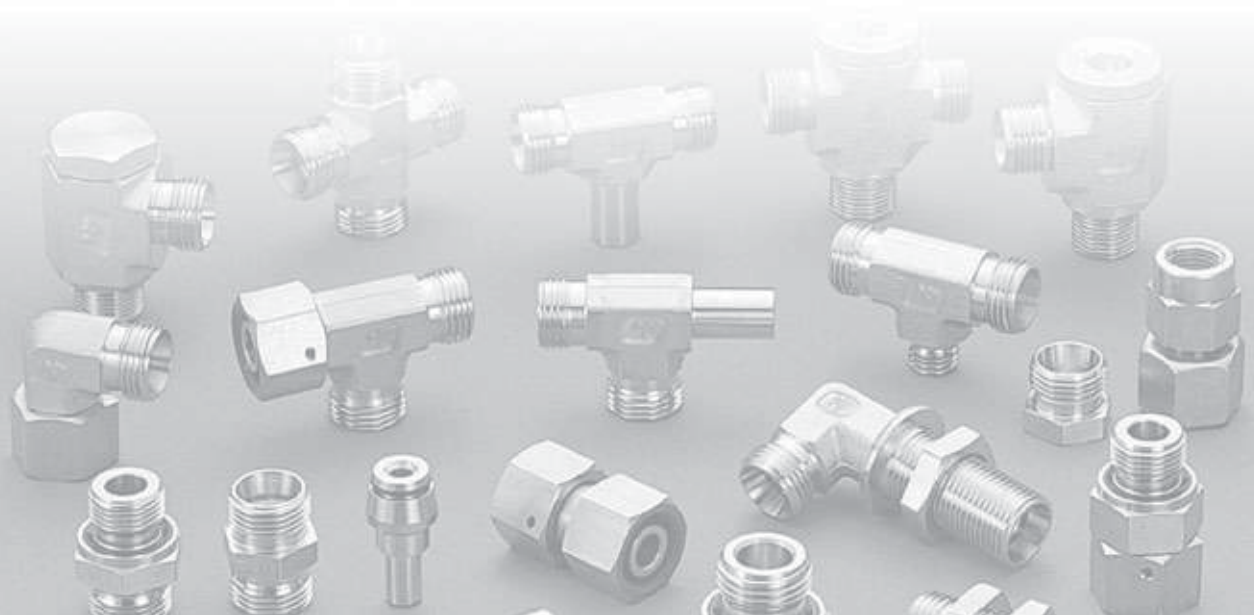
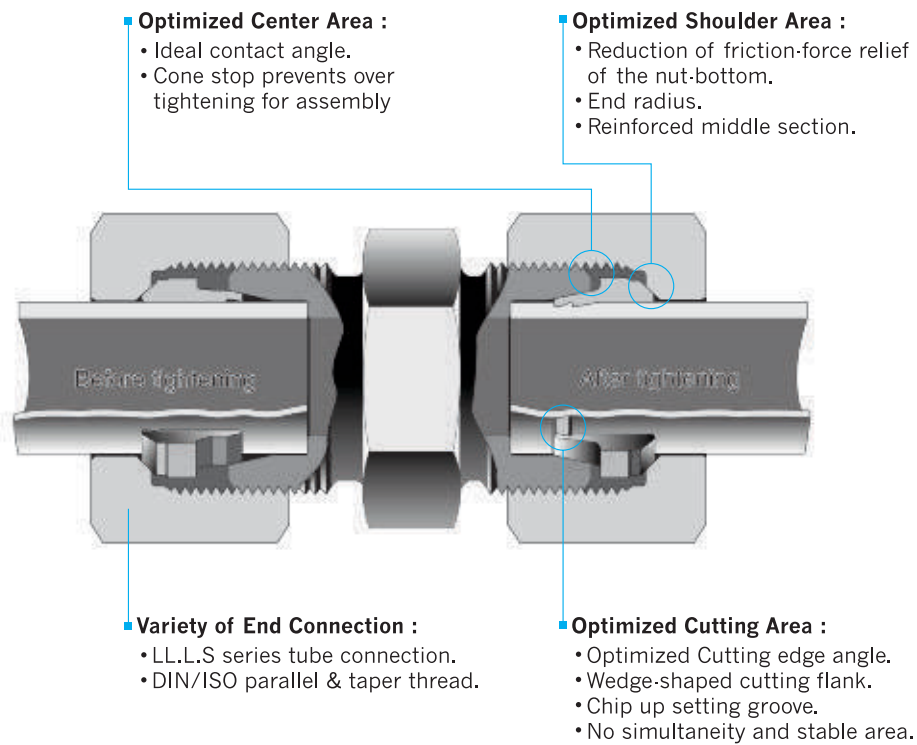

## General

Hy-Lok Corp. DIN fittings based on Standard DIN 3851 have been improved to comply with current standard requirements. They conform to installation standard ISO 8434 part1 and DIN 2353 and all constituent parts are interchangeable with other brands. Hy-Lok Corp. has many years of experience in the manufacture of precision products which is in conjunction with stringent quality control from the starting material up to the finished component determines the quality of Hy-Lok Corp. fittings.

## Fitting materials

Hy-Lok Corp. Fittings are machined from drawn steel bar or steel forgings.

Materials are according to DIN 3859 (technical specifications for tube fittings).

Nuts are either cold or hot pressed.

Fittings made of stainless steel X6CrNiMoTi 17122 to DIN 17440, material No. 1.4571, or ASTM A479 type 316 are also available for supply.

**Caution!** *The use of steel is permissible up to 120°C max. For any temperature higher than 120°C, use material 1.4571.*

## Stressability of pressure and temperature for Hy-Lok tube fittings

Pressure specification

The pressure specifications, given in our catalog relate to steel fittings with a static load at a temperature up to 120°C and refer to

- Nominal pressure (PN) according to DIN 2401.  
The rated pressure has a safety factor of 4(DIN 3859)
- Permissible working pressure (PB) of the operating pressure is according to DIN 2401. The safety factor for PB is 2,5 or 1.5 respectively.

### Pressure Range

Series	Pressure
LL	Up to 100 bar
L	Up to 500 bar
S	Up to 800 bar

## Allowable working temperatures (TB)

A) For fitting materials

Material	Temperature
Steel	-40°C up to +120°C (DIN 3859)
Brass	-60°C up to +175°C
Stainless Steel	-60°C up to +400°C (DIN 17440)

Please refer to the information given in the section "Reduction of Pressure"

B) For seal materials

Material	Temperature
NBR(e.g.Perbunan®)	-35°C up to +100°C
FPM(e.g.Vitor®)	-25°C up to +200°C
PTFE(e.g.Teflon®)	-60°C up to +240°C

**Caution!** *If different fitting and sealing material is used, the lowest temperature as indicated for each material is applicable!*

## Pressure reduction with temperature

The reduction of pressure is necessary for operating at lower or higher temperature.

Materials of fittings	Temperature range	Reduction of pressure
Steel	-40°C up to +120°C	-
Brass	-60°C up to +175°C	35%
1.4571	-60°C up to +20°C	-
1.4571	-60°C up to +50°C	4%
1.4571	+100°C	11%
1.4571	+200°C	20%
1.4571	+300°C	29%
1.4571	+400°C	33%

For different material of tubes and fittings, tubes must be tested separately considering the allowed temperature range and the required reduction of pressure.

## Surface protection

All range of fittings are CR(VI) - free Surface treatment.  
All weldable fittings are phosphated.  
Carbon steel can be plated with nickel on request.

## Fluids

Hy-Lok Corp. DIN fittings are designed for the use of commercial hydraulic oils. If it is special fluids, please contact our technical support team.

## 24° Tube Fittings-DIN 2353 & ISO 8434-1

### Tubing guide

#### Seamless precision steel tube St 37.4

We recommend the use of seamless precision steel tubes with dimensions to DIN 2391, part 1, material conforming St. 37.4 to DIN 1630, NBK.

Tube O.D (D)	Tolerance	Wall* Thickness (t)	Weight	Design Pressure	
				DIN 2413	
				I	III
mm	mm	mm	kg/m	bar	bar
4	±0,1	0,5	0,047	313	274
4		0,75	0,060	409	391
4		1	0,074	522	500
6	±0,1	• 0,75	0,103	333	289
6		1	0,123	389	372
6		1,5	0,166	549	526
6		2	0,197	692	662
6		2,25	0,208	757	725
8	±0,1	1	0,173	333	288
8		1,5	0,240	431	412
8		2	0,296	549	526
8		2,5	0,339	658	630
10	±0,1	1	0,222	282	248
10		1,5	0,314	373	357
10		2	0,395	478	458
10		2,5	0,462	576	551
10		3	0,518	666	638
12	±0,08	• 1	0,271	235	209
12		1,5	0,389	353	303
12		2	0,493	409	391
12		2,5	0,586	495	474
12		3	0,606	576	551
12	3,5	0,734	651	624	
15	±0,08	• 1	0,345	188	171
15		1,5	0,499	282	248
15		2	0,641	336	321
15		2,5	0,771	409	391
15		3	0,888	478	458
16	±0,08	• 1	0,370	176	160
16		1,5	0,536	264	234
16		2	0,691	353	303
16		2,5	0,832	386	370
16		3	0,962	452	433
18	±0,08	• 1	0,419	157	143
18		1,5	0,610	235	209
18		2	0,789	313	273
18		2,5	0,956	348	333
18		3	1,110	409	391

Tube O.D (D)	Tolerance	Wall* Thickness (t)	Weight	Design Pressure	
				DIN 2413	
				I	III
mm	mm	mm	kg/m	bar	bar
20	±0,08	• 1,5	0,684	212	191
20		2	0,888	282	249
20		2,5	1,08	353	303
20		3	1,26	373	357
20		3,5	1,424	426	408
20	4	1,578	478	458	
22	±0,08	• 1	0,518	128	118
22		1,5	0,758	192	174
22		2	0,986	256	227
22		2,5	1,202	320	278
22	3	1,406	343	328	
25	±0,08	2	1,134	226	201
25		2,5	1,387	282	248
25		3	1,628	338	292
25		4	2,072	394	378
25		4,5	2,275	437	418
25	5	2,466	478	458	
28	±0,08	1,5	0,980	151	139
28		2	1,282	201	181
28		2,5	1,572	252	223
28		3	1,850	302	264
28		4	2,368	357	342
28	5	2,836	434	415	
30	±0,08	• 2	1,381	188	171
30		2,5	1,695	235	210
30		3	2,00	282	248
30		4	2,57	336	321
30		5	3,08	409	391
35	±0,08	2	1,63	161	147
35		2,5	2,00	201	181
35		3	2,37	242	215
35		4	3,06	322	280
35		5	3,69	357	342
35		6	4,29	419	401
38	±0,15	• 2,5	2,189	186	168
38		3	2,589	223	200
38		4	3,35	297	260
38		5	4,07	332	318
38		6	4,74	390	373
38		7	5,35	446	427
42		±0,2	• 2	1,973	134
42	3		2,89	201	181
42	4		3,75	269	237

Reinforced tube inserts are recommended where thin-wall tubes are subject to severe strains.

\* Permissible variation in wall thickness (DIN 2391)

#### ■ Calculation Pressures :

- Calculated pressures to DIN 2413 part I for primarily static load conditions.
- Yield point (K) : 235 N/mm<sup>2</sup> (to DIN 1630)
- Safety factor (S) : 1.5
- Allowance factor (C)

$$P = \frac{20 \cdot K \cdot t \cdot c}{S \cdot D} \text{ (bar)}$$

- Calculated pressures to DIN 2413 part III for dynamic load conditions
- Yield point (K) : 225 N/mm<sup>2</sup> (DIN 2413 4.2.8)
- Safety factor (S) : 1.5

$$P = \frac{20 \cdot K \cdot t \cdot c}{S \cdot (D + t \cdot c)} \text{ (bar)}$$

Factor for consideration of wall thickness divergence for static and dynamic stress

Tube Range	4mm / 5mm	6mm / 8mm	Larger
Factor(c)	0.8	0.85	0.9

#### ■ Note

For a diameter ratio of O.D / I.D > 1.35, calculation was made to DIN 2413 part III and based on a pulsating fatigue limit of 235 N/mm<sup>2</sup>

- Temperature range : -40°C to + 120°C without reduction in pressure.

**Seamless precision stainless steel 1.4571**

Stainless steel tubes (e.g. 1.4571), code X6CrNiMoTi 17122, must be cold-drawn seamless and heat-treated without formation of scale to Din 17458 with tolerances to DIN 2391, part 1.

The following tube wall thickness are suitable for use :

Tube O.D (D)	Tolerance	Wall* Thickness (t)	Weight	Design Pressure	
				DIN 2413	
				I	III
mm	mm	mm	kg/m	bar	bar
4	±0.1	0.75	0.061	391	376
4		1	0.075	500	480
6	±0.1	1	0.125	372	357
6		1.5	0.168	526	505
6		2	0.200	662	637
6		2.25	0.211	725	696
8	±0.1	1	0.175	347	277
8		1.5	0.244	412	396
8		2	0.300	526	505
8		2.5	0.344	630	604
10	±0.1	1	0.225	294	238
10		1.5	0.319	357	343
10		2	0.401	458	439
10		2.5	0.469	551	529
10		3	0.525	638	612
12	±0.08	•1	0.275	245	201
12		1.5	0.394	368	291
12		2	0.501	391	376
12		2.5	0.594	474	455
12		3	0.615	551	529
12		3.5	0.744	624	599
15	±0.08	1.5	0.507	294	238
15		2	0.651	321	309
15		2.5	0.782	391	376
15		3	0.901	458	439
16	±0.08	2	0.701	368	291
16		2.5	0.845	370	355
16		3	0.977	433	416
18	±0.08	•1.5	0.620	245	201
18		2	0.801	327	262
18		2.5	0.967	333	320
18		3	1.126	391	376

Tube O.D (D)	Tolerance	Wall* Thickness (t)	Weight	Design Pressure	
				DIN 2413	
				I	III
mm	mm	mm	kg/m	bar	bar
20	±0.08	2.5	1.095	368	291
20		3	1.277	357	343
20		3.5	1.443	408	392
20		4	1.600	458	439
22	±0.08	•2	1.002	267	218
22		2.5	1.220	334	267
22		3	1.426	328	315
25	±0.08	•2.5	1.152	235	193
25		2.5	1.408	294	238
25		3	1.635	353	281
25		4	2.092	378	363
25		4.5	2.307	418	402
25	5	2.501	458	439	
28	±0.08	2	1.302	210	174
28		2.5	1.594	263	214
28		3	1.874	315	253
28		4	2.402	342	328
28		5	2.876	415	399
30	±0.08	3	2.028	294	238
30		4	2.605	321	309
30		5	3.400	391	376
35	±0.15	2	1.644	168	141
35		2.5	2.018	210	174
35		3	2.392	252	206
35		4	3.086	336	269
35		5	3.742	342	328
35		6	4.351	401	385
38	±0.15	4	3.405	309	249
38		5	4.131	318	305
38		6	4.807	373	358
38		7	5.426	427	410
42	±0.2	3	2.930	210	174
42		4	3.798	280	227

- Reinforced tube inserts are recommended where thin-wall tubes are subject to severe strains.

\* Permissible variation in wall thickness (DIN 2391)

■ Calculation Pressures :

- Calculated pressures to DIN 2413 part I for primarily static load conditions.
- Yield point (K) : 245 N/mm<sup>2</sup> (to DIN 17458)
- Safety factor (S) : 1.5
- Allowance factor (C)

$$P = \frac{20 \cdot K \cdot t \cdot c}{S \cdot D} \text{ (bar)}$$

- Calculated pressures to DIN 2413 part III for dynamic load conditions
- Yield point (K) : 216 N/mm<sup>2</sup> (assumed value)
- Safety factor (S) : 1.5

$$P = \frac{20 \cdot K \cdot t \cdot c}{S \cdot (D + t \cdot c)} \text{ (bar)}$$

Factor for consideration of wall thickness divergence for static and dynamic stress

Tube Range	4mm / 5mm	6mm / 8mm	Larger
Factor(c)	0.8	0.85	0.9

■ Note

For a diameter ratio of O.D / I.D > 1.35, calculation was made to DIN 2413 part III and based on a pulsating fatigue limit of 225 N/mm<sup>2</sup>

- Temperature range : -60°C to + 400°C

Reduction in pressure for higher temperatures (See page 3)

## Stud Ends & Tapped Hole Forms for tube Fittings

This standard specifies dimensions for stud ends and tapped holes with metric fine pitch thread and pipe thread for use with compression fittings, valves and screw plugs.

### Forms of Stud Ends

**Form A** (DIN 3852 Part 1+2)  
with sealing by washer

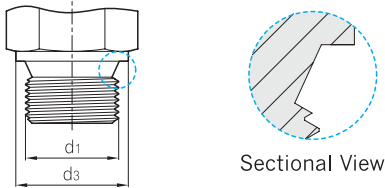

**Form B** (DIN 3852 Part 1+2)  
with sealing by compression  
against face of body



**Form C** (DIN 3852 Part 1+2)  
with sealing in tapered thread

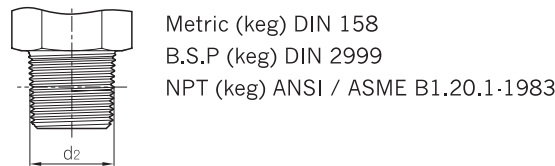

**Form E** (DIN 3852 Part 11)  
with sealing by DIN 3869 ring seals (\*ED-Ring)

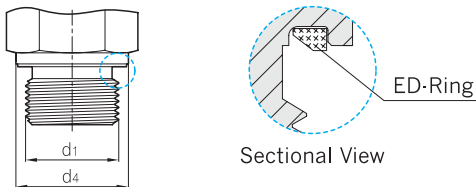

**Form F** (DIN 3852 Part 3)  
with sealing by \*O-Ring

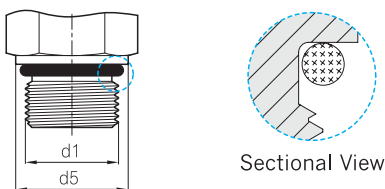

Thread size		d <sub>3</sub>	d <sub>4</sub> <sup>0/-0.2</sup>	d <sub>5</sub> ±0.1
Form A,B and E,F stud ends d <sub>1</sub>	Form C stud ends d <sub>2</sub>			
M 8 x 1.0	M 8 x 1.0 keg.	-	-	10.9
M10 x 1.0	M10 x 1.0 keg.	14	13.9	12.9
M12 x 1.5	M12 x 1.5 keg.	17	16.9	16.9
M14 x 1.5	M14 x 1.5 keg.	19	18.9	18.9
M16 x 1.5	M16 x 1.5 keg.	21	21.9	20.9
M18 x 1.5	M18 x 1.5 keg.	23	23.9	22.9
M20 x 1.5	M20 x 1.5 keg.	25	25.9	24.9
M22 x 1.5	M22 x 1.5 keg.	27	26.9	26.9
M26 x 1.5	-	31	31.9	30.9
M27 x 2.0	-	32	31.9	31.9
M33 x 2.0	-	39	39.9	37.9
M42 x 2.0	-	49	49.9	47.9
M48 x 2.0	-	55	54.9	54.9
G 1/8	1/8 NPT	14	13.9	-
G 1/4	1/4 NPT	18	18.9	-
G 3/8	3/8 NPT	22	21.9	-
G 1/2	1/2 NPT	26	26.9	-
G 3/4	3/4 NPT	32	31.9	-
G 1	1 NPT	39	39.9	-
G 1 1/4	1 1/4 NPT	49	49.9	-
G 1 1/2	1 1/2 NPT	55	54.9	-
7/16 - 20UNF	R 1/8 keg.	-	-	14.4
9/16 - 18UNF	R 1/4 keg.	-	-	17.6
3/4 - 16UNF	R 3/8 keg.	-	-	22.3
7/8 - 14UNF	R 1/2 keg.	-	-	25.5
1 1/16 - 12UN	R 3/4 keg.	-	-	31.9
1 5/16 - 12UN	R 1 keg.	-	-	38.2
1 5/8 - 12UN	R 1 1/4 keg.	-	-	47.7
-	R 1 1/2 keg.	-	-	-

\* ED-Ring & O-Ring Seals are made in compliance with NBR Standard (-20°C to 90°C)  
Viton is available on request (-20°C to 200°C)

## Forms of Tapped Holes

**Form X** (DIN 3852 Part 1+2)  
for parallel Stud Ends. (Form A,B)  
\* d<sub>7</sub> is for Stud Ends Form E

**Form W** (DIN 3852 Part 3)  
for Stud Ends with O-Ring. (Form F)

**Form Z** (DIN 3852 Part 1+2)  
for tapered thread Stud Ends.

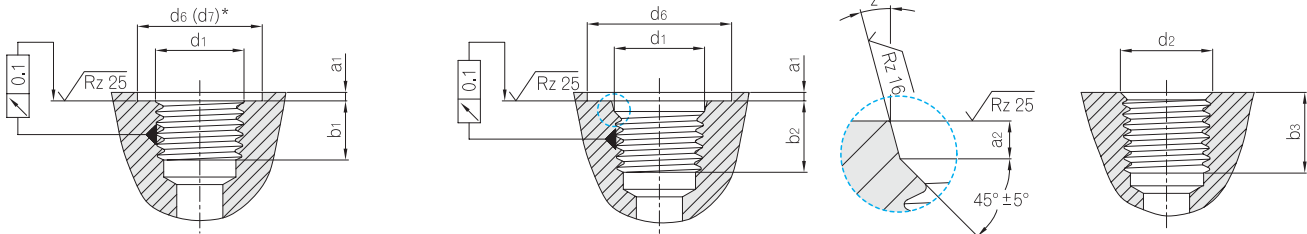

Thread size		d <sub>6</sub>	d <sub>7</sub>	a <sub>6</sub>	a <sub>2</sub> <sup>+0.4</sup> <sub>0</sub>	b <sub>1</sub>	b <sub>2</sub>	b <sub>3</sub>	α <sup>°</sup> <sub>±1°</sub>
Form X,W Tapped Holes d <sub>1</sub>	Form Z Tapped Holes d <sub>2</sub>	min		max		min	min	min	
M 8 x 1.0	M 8 x 1.0 keg.	13	-	1.0	1.6	-	10.0	5.5	12
M10 x 1.0	M10 x 1.0 keg.	15	15	1.0	1.6	8	10.0	5.5	12
M12 x 1.5	M12 x 1.5 keg.	18	18	1.5	2.4	12	11.5	8.5	12
M14 x 1.5	M14 x 1.5 keg.	20	20	1.5	2.4	12	11.5	8.5	15
M16 x 1.5	M16 x 1.5 keg.	22	23	1.5	2.4	12	13.0	8.5	15
M18 x 1.5	M18 x 1.5 keg.	24	25	2.0	2.4	12	14.5	8.5	15
M20 x 1.5	M20 x 1.5 keg.	26	27	2.0	2.4	14	14.0	10.5	15
M22 x 1.5	M22 x 1.5 keg.	28	28	2.5	2.4	14	15.5	10.5	15
M26 x 1.5	-	32	33	2.5	3.1	16	16.0	-	15
M27 x 2.0	-	33	33	2.5	3.1	16	19.0	-	15
M33 x 2.0	-	40	41	2.5	3.1	18	19.0	-	15
M42 x 2.0	-	50	51	2.5	3.1	20	19.5	-	15
M48 x 2.0	-	56	56	2.5	3.1	22	22	-	15
G 1/8	1/8 NPT	15	15	1.0	-	8	-	6.9	-
G 1/4	1/4 NPT	19	20	1.5	-	12	-	10.0	-
G 3/8	3/8 NPT	23	23	2.0	-	12	-	10.3	-
G 1/2	1/2 NPT	27	28	2.5	-	14	-	13.6	-
G 3/4	3/4 NPT	33	33	2.5	-	16	-	14.1	-
G 1	1 NPT	40	41	2.5	-	18	-	16.8	-
G 1 1/4	1 1/4 NPT	50	51	2.5	-	20	-	17.3	-
G 1 1/2	1 1/2 NPT	56	56	2.5	-	22	-	17.3	-
7/16 - 20UNF	R 1/8 keg.	21	-	1.6	2.4	-	11.5	5.5	12
9/16 - 18UNF	R 1/4 keg.	25	-	1.6	2.5	-	12.7	8.5	12
3/4 - 16UNF	R 3/8 keg.	30	-	2.4	2.5	-	14.3	8.5	15
7/8 - 14UNF	R 1/2 keg.	34	-	2.4	2.5	-	16.7	10.5	15
1 1/16 - 12UN	R 3/4 keg.	41	-	2.4	3.3	-	19.0	13.0	15
1 5/16 - 12UN	R 1 keg.	49	-	3.2	3.3	-	19.0	16.0	15
1 5/8 - 12UN	R 1 1/4 keg.	58	-	3.2	3.3	-	19.0	17.0	15
-	R 1 1/2 keg.	-	-	-	-	-	-	17.0	-

## 24° Tube Fittings-DIN 2353 & ISO 8434-1

### Tightening Torques for Studs

- Recommend tightening torques MA  
The table below shows the Nm value for studs to avoid leakages.
- Sealing of taper thread  
Taper threads are not self-sealing. To achieve a leakproof seal an additional sealant is necessary.  
A well-established sealing-medium is PTFE-tape(e.g.Teflon)
- Note  
The quoted figures relate to fittings out of steel(galvanized) and to counterpart made of steel.  
Lubricate stud with hydraulic oil before screwing in.

unit : MA(Nm)

BSPP straight port connections			Straight male stud fittings with port tapping					Banjo fittings		Adjustable ends		Blanking plugs		Non-return valves
Series	Tube O.D	T Thread Size	Form A for sealing washer	Form B with face	Form E with ED sealing	Form F with O-ring sealing	O-ring with sealing and retaining ring	DWH / DTH	DSWVE	O-ring and retaining ring	O-ring	DVSTI-ED with ED sealing	DCV with ED sealing	
L	6	1/8	9	18	18	18	18	18	18	18	18	13	18	
	8	1/4	35	35	35	35	35	45	40	35	35	30	35	
	10	1/4	35	35	35	35	35	45	40	35	35		35	
	12	3/8	45	70	70	70	70	70	65	70	70	60	50	
	15	1/2	65	140	140	90	90	120	90	110	110	80	85	
	18	1/2	65	100	100	90	90	120	90	110	110		65	
	22	3/4	90	180	180	180	180	230	125	180	180	140	140	
	28	1	150	330	330	310	310	320		310	310	200	190	
	35	1 1/4	240	540	540	450	450	540		450	450	400	360	
42	1 1/2	290	630	630	540	540	700		540	540	450	540		
S	6	1/4	35	55	40	40		45	40	55	55		45	
	8	1/4	35	55	40	40		45	40	55	55		45	
	10	3/8	45	90	80	80		70	65	90	90		60	
	12	3/8	45	90	80	80		70	65	90	90		60	
	14	1/2	65	150	115	115		120	90	110	110		145	
	16	1/2	65	130	115	115		120	90	110	110		100	
	20	3/4	90	270	180	180		230	125	115	115		145	
	25	1	150	340	310	310		320		420	420		260	
	30	1 1/4	240	540	450	450		540		550	550		360	
38	1 1/2	290	700	540	540		700		600	600		540		

unit : MA(Nm)

Metric straight port connections			Straight male stud fittings with port tapping					Banjo fittings		Adjustable ends		Blanking plugs		Non-return valves
Series	Tube O.D	Thread Size	Form A for sealing washer	Form B with face	Form E with ED sealing	Form F with O-ring sealing	O-ring with sealing and retaining ring	DWH / DTH	DSWVE	O-ring and retaining ring	O-ring	DVSTI-ED with ED sealing	DVSTI with O-ring sealing	DCV with ED sealing
L	6	M10x1.0	9	18	18	15	18	18	18	18	15	12	20	18
	8	M12x1.5	20	30	25	25	35	45	35	35	25	25		25
	10	M14x1.5	35	45	45	35	45	55	50	45	35	35		35
	12	M16x1.5	45	65	55	40	55	80	60	55	40	50		50
	15	M18x1.5	55	80	70	45	70	100	80	70	45	65		70
	18	M22x1.5	65	140	125	60	160	140	120	180	60	90		125
	22	M26x1.5	90	190	180	100	250	320	130	180	100	135		145
	28	M33x2.0	150	340	310	160	310	360		310	160	225		210
	35	M42x2.0	240	500	450	210	450	540		450	210	360		360
42	M48x2.0	290	630	540	260	540	700		600	260	360		540	
S	6	M12x1.5	20	35	40	35		45	35	35	35		35	35
	8	M14x1.5	35	55	40	45		55	50	60	45		45	45
	10	M16x1.5	45	70	70	55		80	60	95	55		55	55
	12	M18x1.5	55	110	90	70		100	80	120	90		70	70
	14	M20x1.5	55	150	125	80		125	110			80	80	100
	16	M22x1.5	65	170	135	100		135	120	190	100		100	125
	20	M27x2.0	90	270	180	170		320	135	190	170		170	135
	25	M33x2.0	150	410	310	310		360		500	310		310	210
	30	M42x2.0	240	540	450	330		540		600	330		330	360
38	M48x2.0	290	700	540	420		700		600	420		420	540	



## Ordering Information

Example 1. Tube to Tube Connection

DT - 12 S - S316  
 ①            ② ③            ⑥

Example 3. Tube to Tube Port

DEW - 16 S - S316  
 ①            ② ③            ⑥

Example 5. Banjo Fitting

DWH - 16 S - 04G - S316  
 ①            ② ③            ④            ⑥

Example 2. Tube to Thread Connection

DMC - 10 L - 02G ED - S316  
 ①            ② ③            ④ ⑤            ⑥

Example 4. Tube Port to Female Port

DMC - 16 S - 04G ED - STEL  
 ①            ② ③            ④ ⑤            ⑥

Example 6. Male / Female Adapter

MFAE - 04G . 03G - STEL  
 ①            ④            ⑥

- ① Name of Fitting : "Refer to Index"
- ② Tube O.D : See Tube O.D Designator
- ③ Series : See Series Designator
- ④ Thread Connection : See Thread Designator
- ⑤ Elastomer Seal : ED-Ring (Refer to seal materials)
- ⑥ Material : See Material Designator

### Tube O.D Designator

Tube O.D	4mm	6mm	8mm	.....	38mm	42mm
Identifier	04	06	08	.....	38	42

### Series Designator

Series	Very Light	Light	Heavy
Identifier	LL	L	S

### Thread Designator (Pipe Thread)

Nominal Size		1/8"	1/4"	3/8"	1/2"	3/4"	1"	1 1/4"	1 1/2"
Identifier	ANSI / ASME B1.20.1 NPT	01N	02N	03N	04N	06N	08N	10N	12N
	DIN-ISO228(DIN 259) BSP/Parallel	01G	02G	03G	04G	06G	08G	10G	12G
	DIN-2999 BSP Tapered	01R	02R	03R	04R	06R	08R	10R	12R

### Thread Designator (Metric Thread)

Metric Size		M8 x 1.0	M10 x 1.0	M12 x 1.5	M14 x 1.5	.....	M27 x 2.0	M33 x 2.0	M42 x 2.0	M48 x 2.0
Identifier	DIN 158 Taper (Keg)	M8K	M10K	M12K	M14K	.....				
	DIN-13 Parallel	M8	M10	M12	M14	.....	M27	M33	M42	M48









### Thread Designator (Unified)

Size	7/16-20UNF	9/16-18UNF	3/4-16UNF	7/8-14UNF	1 1/16-12UN	1 5/16-12UN	1 5/8-12UN
Identifier	04U	06U	08U	10U	12U	16U	20U

### Material Designator

Material	Carbon Steel (DIN 3859)	Stainless Steel		Brass
		DIN 17440 / 1.4571	ASTM A479 TYPE 316	
Identifier	STEL	4571	S316	BRAS

## 24° Tube Fittings-DIN 2353 & ISO 8434-1

Tube to Tube		Page	EO	EMB	VOLZ	VOSS	WALPRO
	<b>DU</b> ..... 15 Straight Union	15	G	E	G-V	111... 112...	P-GV
	<b>DL</b> ..... 15 Union Elbow	15	W	F	W-V	119... 120...	P-WV
	<b>DUR</b> ..... 16 Reducing Union	16	GR	ER	GR-V		P-GV
	<b>DT</b> ..... 17 Union Tee	17	T	G	T-V	133... 134...	P-TV
	<b>DC</b> ..... 17 Union Cross	17	K	H	K-V	135... 136...	P-KV
	<b>DTR</b> ..... 18 Reducing Tee	18	TR	GR			P-TV
	<b>DBU</b> ..... 19 Bulkhead Union	19	SV	K	GS-V	137...	P-GSV
	<b>DBUW</b> ..... 19 Welding Bulkhead Union	19	ESV	N	ES-V	141...	P-ESV
	<b>DBL</b> ..... 20 Bulkhead Union Elbow	20	WSV	L	WS-V	138...	P-WSV

## Tube to Female Port









	<b>DOM-U / M</b> ..... 21 Male Connector (UNF / Metric) with O-Ring	GE-UNF / UN GEO	A / UNF / UN A / O		182...	P-GEV.U P-GEV.M-FO.F
	<b>DMC-G</b> ..... 22 Male Connector (ISO/BSP Tapered)	GE-R	AP-R	GE-V..RK	103...104...	P-GEV..RK
	<b>DMC-R</b> ..... 23 Male Connector (ISO/BSP Parallel)	GE-R	A-R	GE-V..R	110...	P-GEV..R
	<b>DMC-M</b> ..... 24 Male Connector (Metric)	GE-M	A-M	GE-V..M	109...	P-GEV..M
	<b>DMC-GED</b> ..... 25 Male Connector (ISO/BSP Parallel) with ED-Ring	GE-R-ED	A-RWD	GE-V..RWD	184...	P-GEV..R-WD
	<b>DMC-MED</b> ..... 26 Male Connector (Metric) with ED-Ring	GE-M-ED	A-MWD	GE-V..MWD	184...	P-GEV..M-WD
	<b>DMC-N</b> ..... 27 Male Connector (NPT)	GE-NPT	A/NPT	GE-V..NPT	105...106	P-GEV..NPT
	<b>DLM-R / M</b> ..... 28 Male Elbow (ISO/BSP Tapered / Metric)	WE-R -M	B-R -M	WE-V..R ..M	115...116... 113...114...	P-WEV..RK ..MK

Illustration chart for reference only

**Tube to Male Thread**

	Page	EO	EMB	VOLZ	VOSS	WALPRO
 <b>DFC-G / M</b> ..... 29 Female Connector (ISO/BSP Parallel / Metric)	29	GAI-R -M	AL-R -M	GAIV..R ..M	144... 143...	P-GAV..R ..M

**Tube to Tube Port (Adjustable Fittings)**

 <b>DLA</b> ..... 30 Adjustable Elbow	30	EVW	VB	EW-V	158...	P-EWV-SV
 <b>DBTA</b> ..... 30 Adjustable Branch Tee	30	EVT	VC	ET-V	160...	P-ETV-SV
 <b>DRTA</b> ..... 31 Adjustable Run Tee	31	EVL	VD	EL-V	162...	P-ELV-SV
 <b>DEW</b> ..... 31 Swivel Adjustable Elbow	31	EW	VBDKO	EWVD		P-EWVD
 <b>DET</b> ..... 32 Swivel Adjustable Branch Tee	32	ET	VCDKO	ETVD		P-ETVD
 <b>DEL</b> ..... 32 Swivel Adjustable Run Tee	32	EL	VDDKO	ELVD		P-ELVD
 <b>DKOR</b> ..... 33 Stand Pipe Reducer	33	KOR	RL,RS			
 <b>DR</b> ..... 34 Reducer	34	KOR		KOR-V	148...78	P-REDV-SV
 <b>DRED</b> ..... 35 Swivel Reducing Tube Adaptor	35	RED	RLDKO RSDKO	REDV		P-REDVD

**Tube Port To Female Port**









 <b>DA-GED / MED</b> ..... 36 Adaptor (ISO/BSP Parallel / Metric) with ED-Ring	36	EVGE-R-ED -M-ED	VA-RWD -MWD	EG-V ..RWD ..MWD	177... 174...	P-EGES..R-WD-SV ..M-WD-SV
 <b>DEGE-G / M</b> ..... 37 Swivel Adaptor (ISO/BSP Parallel / Metric) with ED-Ring	37	EGE-R-ED -M-ED	VADKO-RWD MWD	EGVD ..RWD ..MWD		EGESD..R-WD ..M..WD

Illustration chart for reference only

## 24° Tube Fittings-DIN 2353 & ISO 8434-1

Tube Port to Tube Port		Page	EO	EMB	VOLZ	VOSS	WALPRO
	<b>DUE</b> ..... 38 Swivel Union		GE	EDKO	EDKV		SNV

### Banjo Fittings

	<b>DSWVE-G / M</b> ..... 39 Banjo Fitting (ISO/BSP Parallel / Metric)	SWVE-R -M	SBD-R -M		152.../153... 150.../151...	
	<b>DWH-G / M</b> ..... 40 High Pressure Banjo Fitting (ISO/BSP Parallel / Metric)	WH-R -M	SBE-R -M	EWHV...R -...M	157... 155...	P-RSWV..R ..M
	<b>DTH-G / M</b> ..... 41 High Pressure Banjo Fitting (ISO/BSP Parallel / Metric)	TH-R -M	SGE-R -M	ETHV...R -...M		P-RSTV..R ..V
	<b>DSVW-G / M</b> ..... 42 Throttlefree Banjo Fitting (ISO/BSP Parallel / Metric)	DSVW-R -M	SB-R -B			
	<b>DSVT-G / M</b> ..... 43 Throttlefree Banjo Fitting (ISO/BSP Parallel / Metric)	DSVT-R -M	SG-R -M			

### Gauge Connector & Test Couplings













	<b>DGC-G</b> ..... 44 Pressure Gauge Connector (ISO/BSP Parallel)	MAV	O	MA-V...R	142...	V-MAV...R
	<b>DGE-G</b> ..... 44 Swivel Gauge Adaptor (ISO/BSP Parallel)	MAVE	VODKO	MAVD...R		EMASD...
	<b>DGA-G</b> ..... 44 Gauge Adaptor (ISO/BSP Parallel)			MAEV...R		P-EMAS...R-SV
	<b>DGMA</b> ..... 45 Tee Test Coupling with Threaded Connection M16	GMA3				
	<b>DEMA</b> ..... 45 Test Coupling with Threaded Connection M16	EMA3				





Illustration chart for reference only

Weld Fittings		Page	EO	EMB	VOLZ	VOSS	WALPRO
	<b>DAS</b> ..... 46 Welding Connector	46	AS	V	GAS-V	139...	P-ASV
	<b>DASK</b> ..... 46 Welding Connector	46	ASK	ESNO	ASKK..OD		
	<b>DAK</b> ..... 47 Welding Nipple	47	SKA	SNO	SK-A..OD	070...	SN
	<b>DAK</b> ..... 47 Reducing Welding Nipple	47	SKAR	SNR			

### Male & Female Adaptors

	<b>H-MFAD</b> ..... 49 Male Female Adaptor	49	RI	RI	RIAS	149...	RED
	<b>H-MFAE</b> ..... 49 Male Female Adaptor	49	RI	RI	RIBS	149...	RED
	<b>H-MFAD-ED</b> ..... 50 Male Female Adaptor with ED-Ring	50	RI-ED	RI-WD	RIAS..WD		RED...WD
	<b>H-MFAE-ED</b> ..... 50 Male Female Adaptor with ED-Ring	50	RI-ED	RI-WD	RIBS..WD		RED...WD

### Plugs and Caps

	<b>DVSTI-GED/MED</b> ..... 51 Blanking Plug (ISO/BSP Parallel / Metric) with ED-Ring for ports	51	VSIT R-ED M-ED	VSCH ·RWD ·MWD	VSCH..WD	189...	
	<b>DVSTI</b> ..... 51 Blanking Plug (Metric) with O-Ring for ports	51	VSIT M-OR				
	<b>DVKA</b> ..... 52 Blanking Plug with O-Ring	52	VKA	STO-O	VSTO...OD		VS...
	<b>DCA</b> ..... 52 Tube Cap	52	ROV	VSCHK	EVSV		

### Plugs and Caps















	<b>DIL</b> ..... 53 Tube Insert	53	VH	VSH	VS-H	020...	EH
	<b>N-</b> ..... 53 Bulkhead Lock Nut	53	GM	GM	G-M	080...	

Illustration chart for reference only

## 24° Tube Fittings-DIN 2353 & ISO 8434-1

Spare Parts		Page	EO	EMB	VOLZ	VOSS	WALPRO
	<b>DKA</b> ..... 54 Sealing Ring for DWH / DTH and DSWVE		DKA	DKA	DKRA	080...	
	<b>DKAZ</b> ..... 54 Sealing Ring for DSVW and DSVT		DKAZ	DKAD		081...	
	<b>DKI</b> ..... 54 Sealing Ring for DGC / DGE and DGA		DKI	DKI	DKRI	080...	DKR
	<b>KP-B-S</b> ..... 54 ED-Ring		ED		WD-R		
	<b>KP-B-DS</b> ..... 54 O-Ring		OR		OD-R		
	<b>DN</b> ..... 55 Nut		M	M	U-M	004	M
	<b>DS</b> ..... 55 Cutting Ring		DPR	S	S-DR	007...	S-R P-R
	<b>DFSR</b> ..... 56 Functional Soft Sealing Ring		FM				
	<b>DSRR</b> ..... 56 Soft Sealing Ring (with Retaining Ring)						

## Ball Valves

	<b>BVDT-L/S</b> ..... 58 Ball Valves	KH...					P-KHV...
	<b>BVDF-G</b> ..... 58 Ball Valves	KH...					KH-R...
	<b>BVDF-N</b> ..... 58 Ball Valves	KH...NPT					

## Non Return Valves



	<b>DCV</b> ..... 59 Non Return Valves	RHD	RD	RS-V	600...	P-RV
	<b>DCV-GED-L/S MED-L/S</b> ..... 60 Non Return Valves	RHV-R-ED -M-ED	RV-RWD -MWD	RSVV...RWD -..MWD	602... 601...	P-RVV...R-WD ...M-WD
	<b>DCV-L/S-GED L/S-MED</b> ..... 61 Non Return Valves	RHZ-R-ED -M-ED	RZ-RWD -MWD	RSVZ...RWD -..MWD	604... 603...	P-RVZ...R-WD ...M-WD

Illustration chart for reference only

Straight Union  
**DU**

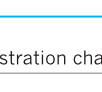
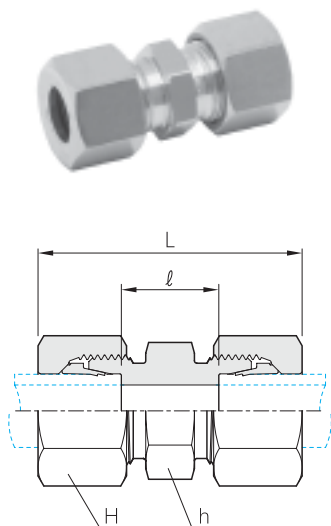

Series	Part No.	Tube O.D.	H	h	L	ℓ	PN(bar)		
							C.Steel	SS316	BRASS
LL	DU - 04LL	4	10	9	31	12	100	100	63
	DU - 06LL	6	12	11	32	9	100	100	63
	DU - 08LL	8	14	12	35	12	100	100	63
	DU - 10LL	10	17	14	35	12	100	100	63
	DU - 12LL	12	19	17	35	11	100	100	63
L	DU - 06L	6	14	12	39	10	500	315	200
	DU - 08L	8	17	14	40	11	500	315	200
	DU - 10L	10	19	17	42	13	500	315	200
	DU - 12L	12	22	19	43	14	400	315	200
	DU - 15L	15	27	24	46	16	400	315	200
	DU - 18L	18	32	27	48	16	400	315	200
	DU - 22L	22	36	32	52	20	250	160	100
	DU - 28L	28	41	41	54	21	250	160	100
	DU - 35L	35	50	46	63	20	250	160	100
	DU - 42L	42	60	55	66	21	250	160	100
S	DU - 06S	6	17	14	45	16	800	630	400
	DU - 08S	8	19	17	47	18	800	630	400
	DU - 10S	10	22	19	49	17	800	630	400
	DU - 12S	12	24	22	51	19	630	630	400
	DU - 14S	14	27	24	57	22	630	630	400
	DU - 16S	16	30	27	57	21	630	400	250
	DU - 20S	20	36	32	66	23	420	400	250
	DU - 25S	25	46	41	74	26	420	400	250
	DU - 30S	30	50	46	80	27	420	400	250
	DU - 38S	38	60	55	90	29	420	315	200

Union Elbow  
**DL**

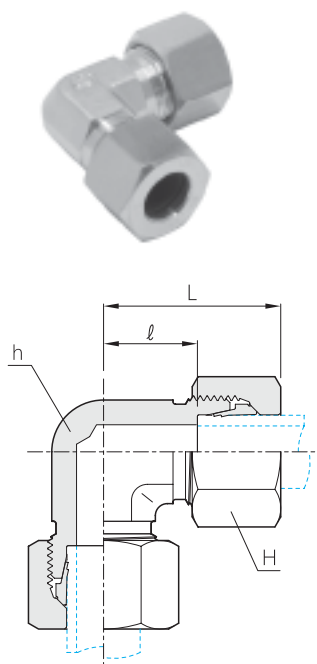

Series	Part No.	Tube O.D.	H	h	L	ℓ	PN(bar)		
							C.Steel	SS316	BRASS
LL	DL - 04LL	4	10	9	21	11.0	100	100	63
	DL - 06LL	6	12	9	21	9.5	100	100	63
	DL - 08LL	8	14	12	23	11.5	100	100	63
	DL - 10LL	10	17	14	24	12.5	100	100	63
	DL - 12LL	12	19	17	25	13.0	100	100	63
L	DL - 06L	6	14	12	27	12.0	500	315	200
	DL - 08L	8	17	12	29	14.0	500	315	200
	DL - 10L	10	19	14	30	15.0	500	315	200
	DL - 12L	12	22	17	32	17.0	400	315	200
	DL - 15L	15	27	19	36	21.0	400	315	200
	DL - 18L	18	32	24	40	23.5	400	315	200
	DL - 22L	22	36	27	44	27.5	250	160	100
	DL - 28L	28	41	36	47	30.5	250	160	100
	DL - 35L	35	50	41	56	34.5	250	160	100
	DL - 42L	42	60	50	63	40.0	250	160	100
S	DL - 06S	6	17	12	31	16.0	800	630	400
	DL - 08S	8	19	14	32	17.0	800	630	400
	DL - 10S	10	22	17	34	17.5	800	630	400
	DL - 12S	12	24	17	38	21.5	630	630	400
	DL - 14S	14	27	19	40	22.0	630	630	400
	DL - 16S	16	30	24	43	24.5	630	400	250
	DL - 20S	20	36	27	48	26.5	420	400	250
	DL - 25S	25	46	36	54	30.0	420	400	250
	DL - 30S	30	50	41	62	35.5	420	400	250
	DL - 38S	38	60	50	72	41.0	420	315	200

Dimensions are given for approximate length with tightened nut, All dimensions are in millimeters for reference only, subject to change.

Reducing Union  
**DUR**

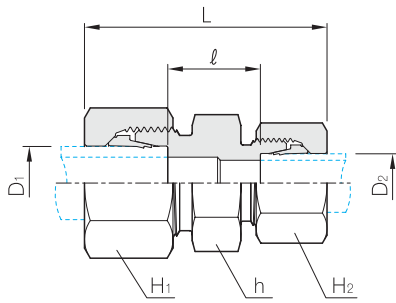
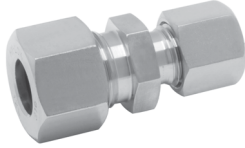

Series	Part No.	Tube O.D.		H <sub>1</sub>	H <sub>2</sub>	h	L	ℓ	PN(bar)		
		D <sub>1</sub>	D <sub>2</sub>						C.Steel	SS316	BRASS
L	DUR 08L - 06L	8	6	17	14	14	40	11.0	500	315	200
	DUR 10L - 06L	10	6	19	14	17	41	12.0	500	315	200
	DUR 10L - 08L	10	8	19	17	17	41	12.0	500	315	200
	DUR 12L - 06L	12	6	22	14	19	42	13.0	400	315	200
	DUR 12L - 08L	12	8	22	17	19	42	13.0	400	315	200
	DUR 12L - 10L	12	10	22	19	19	43	14.0	400	315	200
	DUR 15L - 10L	15	10	27	19	24	45	15.0	400	315	200
	DUR 15L - 12L	15	12	27	22	24	45	15.0	400	315	200
	DUR 18L - 10L	18	10	32	19	27	46	15.5	400	315	200
	DUR 18L - 12L	18	12	32	22	27	46	15.5	400	315	200
	DUR 18L - 15L	18	15	32	27	27	48	16.5	400	315	200
	DUR 22L - 12L	22	12	36	22	32	48	17.5	250	160	100
	DUR 22L - 15L	22	15	36	27	32	50	18.5	250	160	100
	DUR 22L - 18L	22	18	36	32	32	50	18.0	250	160	100
	DUR 28L - 18L	28	18	41	32	41	52	19.0	250	160	100
	DUR 28L - 22L	28	22	41	36	41	54	21.0	250	160	100
DUR 35L - 22L	35	22	50	36	46	59	21.0	250	160	100	
DUR 35L - 28L	35	28	50	41	46	59	21.0	250	160	100	
S	DUR 08S - 06S	8	6	19	17	17	47	18.0	800	630	400
	DUR 10S - 06S	10	6	22	17	19	48	17.5	800	630	400
	DUR 10S - 08S	10	8	22	19	19	48	17.5	800	630	400
	DUR 12S - 06S	12	6	24	17	22	50	19.5	630	630	400
	DUR 12S - 08S	12	8	24	19	22	50	19.5	630	630	400
	DUR 12S - 10S	12	10	24	22	22	51	19.0	630	630	400
	DUR 14S - 10S	14	10	27	22	24	54	20.5	630	630	400
	DUR 14S - 12S	14	12	27	24	24	54	20.5	630	630	400
	DUR 16S - 12S	16	12	30	24	27	54	20.0	630	400	250
	DUR 16S - 14S	16	14	30	27	27	57	21.5	630	400	250
	DUR 20S - 10S	20	10	36	22	32	60	22.0	420	400	250
	DUR 20S - 12S	20	12	36	24	32	60	22.0	420	400	250
	DUR 20S - 16S	20	16	36	30	32	63	23.0	420	400	250
	DUR 25S - 16S	25	16	46	30	41	68	25.0	420	400	250
	DUR 25S - 20S	25	20	46	36	41	71	25.5	420	400	250
	DUR 30S - 20S	30	20	50	36	46	74	26.0	420	400	250
DUR 30S - 25S	30	25	50	46	46	77	26.5	420	400	250	
DUR 38S - 30S	38	30	60	50	55	87	29.5	420	315	200	

Dimensions are given for approximate length with tightened nut. All dimensions are in millimeters for reference only, subject to change.



Union Tee  
**DT**

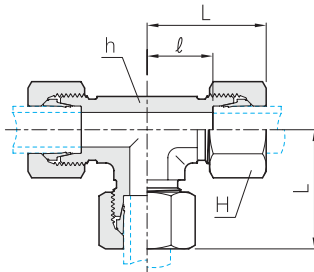
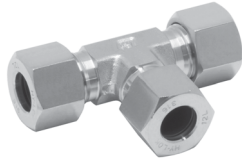

Series	Part No.	Tube O.D.	H	h	L	ℓ	PN(bar)		
							C.Steel	SS316	BRASS
LL	DT - 04LL	4	10	9	21	11.0	100	100	63
	DT - 06LL	6	12	9	21	9.5	100	100	63
	DT - 08LL	8	14	12	23	11.5	100	100	63
	DT - 10LL	10	17	14	24	12.5	100	100	63
	DT - 12LL	12	19	14	27	15.0	100	100	63
L	DT - 06L	6	14	12	27	12.0	500	315	200
	DT - 08L	8	17	12	29	14.0	500	315	200
	DT - 10L	10	19	14	30	15.0	500	315	200
	DT - 12L	12	22	17	32	17.0	400	315	200
	DT - 15L	15	27	19	36	21.0	400	315	200
	DT - 18L	18	32	24	40	23.5	400	315	200
	DT - 22L	22	36	27	44	27.5	250	160	100
	DT - 28L	28	41	36	47	30.5	250	160	100
	DT - 35L	35	50	41	56	34.5	250	160	100
	DT - 42L	42	60	50	63	40.0	250	160	100
S	DT - 06S	6	17	12	31	16.0	800	630	400
	DT - 08S	8	19	14	32	17.0	800	630	400
	DT - 10S	10	22	17	34	17.5	800	630	400
	DT - 12S	12	24	17	38	21.5	630	630	400
	DT - 14S	14	27	19	40	22.0	630	630	400
	DT - 16S	16	30	24	43	24.5	630	400	250
	DT - 20S	20	36	27	48	26.5	420	400	250
	DT - 25S	25	46	36	54	30.0	420	400	250
	DT - 30S	30	50	41	62	35.5	420	400	250
	DT - 38S	38	60	50	72	41.0	420	315	200

Union Cross  
**DC**

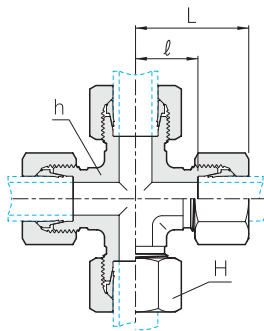
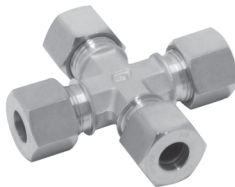

Series	Part No.	Tube O.D.	H	h	L	ℓ	PN(bar)		
							C.Steel	SS316	BRASS
LL	DC - 04LL	4	10	9	21	11.0	100	100	63
	DC - 06LL	6	12	9	21	9.5	100	100	63
	DC - 08LL	8	14	12	23	11.5	100	100	63
	DC - 10LL	10	17	14	24	12.5	100	100	63
	DC - 12LL	12	19	17	27	15.0	100	100	63
L	DC - 06L	6	14	12	27	12.0	315	315	200
	DC - 08L	8	17	12	29	14.0	315	315	200
	DC - 10L	10	19	14	30	15.0	315	315	200
	DC - 12L	12	22	17	32	17.0	315	315	200
	DC - 15L	15	27	19	36	21.0	315	315	200
	DC - 18L	18	32	24	40	23.5	315	315	200
	DC - 22L	22	36	27	44	27.5	160	160	100
	DC - 28L	28	41	36	47	30.5	160	160	100
	DC - 35L	35	50	41	56	34.5	160	160	100
	DC - 42L	42	60	50	63	40.0	160	160	100
S	DC - 06S	6	17	12	31	16.0	630	630	400
	DC - 08S	8	19	14	32	17.0	630	630	400
	DC - 10S	10	22	17	34	17.5	630	630	400
	DC - 12S	12	24	17	38	21.5	630	630	400
	DC - 14S	14	27	19	40	22.0	400	400	250
	DC - 16S	16	30	24	43	24.5	400	400	250
	DC - 20S	20	36	27	48	26.5	315	315	200
	DC - 25S	25	46	36	54	30.0	315	315	200
	DC - 30S	30	50	41	62	35.5	315	315	200
	DC - 38S	38	60	50	72	41.0	315	315	200

Dimensions are given for approximate length with tightened nut, All dimensions are in millimeters for reference only, subject to change.

## 24° Tube Fittings-DIN 2353 & ISO 8434-1

### Reducing Tee **DTR**

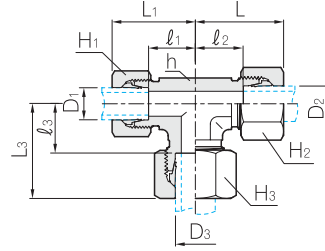
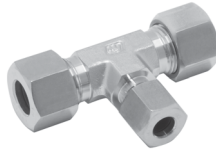

Series	Part No.	Tube O.D.			H <sub>1</sub>	H <sub>2</sub>	H <sub>3</sub>	h	L <sub>1</sub>	L <sub>2</sub>	L <sub>3</sub>	l <sub>1</sub>	l <sub>2</sub>	l <sub>3</sub>	PN(bar)		
		D <sub>1</sub>	D <sub>2</sub>	D <sub>3</sub>											C.Steel	SS316	BRASS
L	DTR 06L-06L-08L	6	6	8	14	14	17	14	29	29	29	14.0	14.0	14.0	500	315	200
	DTR 08L-08L-06L	8	8	6	17	17	14	14	29	29	29	14.0	14.0	14.0	500	315	200
	DTR 06L-06L-10L	6	6	10	14	14	19	14	30	30	30	15.0	15.0	15.0	500	315	200
	DTR 08L-08L-10L	8	8	10	17	17	19	14	30	30	30	15.0	15.0	15.0	500	315	200
	DTR 10L-10L-06L	10	10	6	19	19	14	14	30	30	30	15.0	15.0	15.0	500	315	200
	DTR 10L-10L-08L	10	10	8	19	19	17	14	30	30	30	15.0	15.0	15.0	500	315	200
	DTR 10L-06L-10L	10	16	10	19	14	19	14	30	30	30	15.0	15.0	15.0	500	315	200
	DTR 08L-08L-12L	8	8	12	17	17	22	17	32	32	32	17.0	17.0	17.0	400	315	200
	DTR 12L-12L-06L	12	12	6	22	22	14	17	32	32	32	17.0	17.0	17.0	400	315	200
	DTR 12L-08L-08L	12	18	8	22	17	17	17	32	32	32	17.0	17.0	17.0	400	315	200
	DTR 12L-12L-08L	12	12	8	22	22	17	17	32	32	32	17.0	17.0	17.0	400	315	200
	DTR 12L-10L-10L	12	10	10	22	19	19	17	32	32	32	17.0	17.0	17.0	400	315	200
	DTR 12L-12L-10L	12	12	10	22	22	19	17	32	32	32	17.0	17.0	17.0	400	315	200
	DTR 12L-10L-12L	12	10	12	22	19	22	17	32	32	32	17.0	17.0	17.0	400	315	200
	DTR 10L-10L-15L	10	10	15	19	19	27	19	36	36	36	21.0	21.0	21.0	400	315	200
	DTR 12L-12L-15L	12	12	15	22	22	27	19	36	36	36	21.0	21.0	21.0	400	315	200
	DTR 15L-15L-06L	15	15	6	27	27	14	19	36	36	36	21.0	21.0	21.0	400	315	200
	DTR 15L-15L-10L	15	15	10	27	27	19	19	36	36	36	21.0	21.0	21.0	400	315	200
	DTR 15L-12L-12L	15	12	12	27	22	22	19	36	36	36	21.0	21.0	21.0	400	315	200
	DTR 15L-15L-12L	15	15	12	27	27	22	19	36	36	36	21.0	21.0	21.0	400	315	200
	DTR 15L-12L-15L	15	12	15	27	22	27	19	36	36	36	21.0	21.0	21.0	400	315	200
	DTR 12L-12L-18L	12	12	18	22	22	32	24	39	39	40	24.0	24.0	23.5	400	315	200
	DTR 18L-10L-10L	18	10	10	32	19	19	24	40	39	39	23.5	24.0	24.0	400	315	200
	DTR 18L-18L-10L	18	18	10	32	32	19	24	40	40	39	23.5	23.5	24.0	400	315	200
	DTR 18L-18L-12L	18	18	12	32	32	22	24	40	40	39	23.5	23.5	24.0	400	315	200
	DTR 18L-18L-15L	18	18	15	32	32	27	24	40	40	39	23.5	23.5	24.0	400	315	200
	DTR 18L-10L-18L	18	10	18	32	19	32	24	40	39	40	23.5	24.0	23.5	400	315	200
	DTR 22L-22L-10L	22	22	10	36	36	19	27	44	44	43	27.5	27.5	28.0	250	160	100
	DTR 22L-22L-12L	22	22	12	36	36	22	27	44	44	43	27.5	27.5	28.0	250	160	100
	DTR 22L-15L-15L	22	15	15	36	27	27	27	44	43	43	27.5	28.0	28.0	250	160	100
DTR 22L-22L-15L	22	22	15	36	36	27	27	44	44	43	27.5	27.5	28.0	250	160	100	
DTR 22L-18L-18L	22	18	18	36	32	32	27	44	44	44	27.5	27.5	27.5	250	160	100	
DTR 22L-22L-18L	22	22	18	36	36	32	27	44	44	44	27.5	27.5	27.5	250	160	100	
DTR 22L-18L-22L	22	18	22	36	32	36	27	44	44	44	27.5	27.5	27.5	250	160	100	
DTR 28L-28L-10L	28	28	10	41	41	19	36	47	44	46	30.5	30.5	31.0	250	160	100	
DTR 28L-28L-12L	28	28	12	41	41	22	36	47	47	46	30.5	30.5	31.0	250	160	100	
DTR 28L-28L-15L	28	28	15	41	41	27	36	47	47	46	30.5	30.5	31.0	250	160	100	
DTR 28L-28L-18L	28	28	18	41	41	32	36	47	47	47	30.5	30.5	30.5	250	160	100	
DTR 28L-22L-22L	28	22	22	41	36	36	36	47	47	47	30.5	30.5	30.5	250	160	100	
DTR 28L-28L-22L	28	28	22	41	41	36	36	47	47	47	30.5	30.5	30.5	250	160	100	
S	DTR 10S-10S-06S	10	10	6	22	22	17	17	34	34	33	17.5	17.5	18.0	800	630	400
	DTR 12S-08S-08S	12	18	8	24	19	19	17	38	37	37	21.5	22.0	22.0	630	630	400
	DTR 12S-12S-08S	12	12	8	24	24	19	17	38	38	37	21.5	21.5	22.0	630	630	400
	DTR 12S-12S-10S	12	12	10	24	24	22	17	38	38	38	21.5	21.5	21.5	630	630	400
	DTR 12S-12S-16S	12	12	16	24	24	30	24	42	42	43	25.5	25.5	24.5	630	400	250
	DTR 16S-16S-06S	16	16	6	30	30	17	24	43	43	41	24.5	24.5	26.0	630	400	250
	DTR 16S-16S-08S	16	16	8	30	30	19	24	43	43	41	24.5	24.5	26.0	630	400	250
	DTR 16S-16S-10S	16	16	10	30	30	22	24	43	43	42	24.5	24.5	25.5	630	400	250
	DTR 16S-16S-12S	16	16	12	30	30	24	24	43	43	42	24.5	24.5	25.5	630	400	250
	DTR 16S-16S-20S	16	16	20	30	30	36	27	47	47	48	28.5	28.5	26.5	420	400	250
	DTR 20S-20S-10S	20	20	10	36	36	22	27	48	48	46	26.5	26.5	29.5	420	400	250
	DTR 20S-20S-12S	20	20	12	36	36	24	27	48	48	46	26.5	26.5	29.5	420	400	250
	DTR 20S-20S-16S	20	20	16	36	36	30	27	48	48	47	26.5	26.5	28.5	420	400	250
	DTR 20S-20S-25S	20	20	25	36	36	46	36	53	53	54	31.5	31.5	30.0	420	400	250
	DTR 25S-25S-16S	25	25	16	46	46	30	36	54	54	52	30.0	30.0	33.5	420	400	250
	DTR 25S-25S-20S	25	25	20	46	46	36	36	54	54	53	30.0	30.0	31.5	420	400	250
	DTR 25S-25S-30S	25	25	30	46	46	50	41	61	61	62	37.0	37.0	35.5	420	400	250

Dimensions are given for approximate length with tightened nut. All dimensions are in millimeters for reference only, subject to change.

## Bulkhead Union DBU

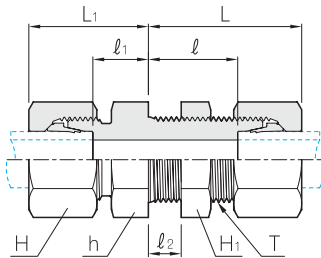
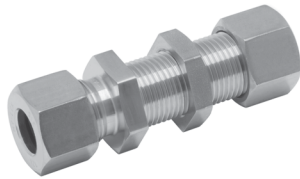

$l_2 = 16\text{mm Max.}$   
 = 3mm Min (06-18L and 06-16S)  
 = 4mm Min (22-42L and 20-38S)

Series	Part No.	Tube O.D.	H	H <sub>1</sub>	h	L	L <sub>1</sub>	ℓ	ℓ <sub>1</sub>	T	PN(bar)		
											C.Steel	SS316	BRASS
L	DBU - 06L	6	14	17	17	42	22	27.0	7.0	M 12 X 1.5	500	315	200
	DBU - 08L	8	17	19	19	42	23	27.0	8.0	M 14 X 1.5	500	315	200
	DBU - 10L	10	19	22	22	43	25	28.0	10.0	M 16 X 1.5	500	315	200
	DBU - 12L	12	22	24	24	44	25	29.0	10.0	M 18 X 1.5	400	315	200
	DBU - 15L	15	27	30	27	46	27	31.0	12.0	M 22 X 1.5	400	315	200
	DBU - 18L	18	32	36	32	49	30	32.5	13.5	M 26 X 1.5	400	315	200
	DBU - 22L	22	36	41	36	51	33	34.5	16.5	M 30 X 2.0	250	160	100
	DBU - 28L	28	41	46	41	52	35	35.5	18.5	M 36 X 2.0	250	160	100
	DBU - 35L	35	50	55	50	58	40	36.5	18.5	M 45 X 2.0	250	160	160
DBU - 42L	42	60	65	60	59	42	36.0	19.0	M 52 X 2.0	250	160	160	
S	DBU - 06S	6	17	19	19	44	27	29.0	12.0	M 14 X 1.5	800	630	400
	DBU - 08S	8	19	22	22	44	28	29.0	13.0	M 16 X 1.5	800	630	400
	DBU - 10S	10	22	24	24	46	31	29.5	14.5	M 18 X 1.5	800	630	400
	DBU - 12S	12	24	27	27	47	31	30.5	14.5	M 20 X 1.5	630	630	400
	DBU - 14S	14	27	30	30	50	35	32.0	17.0	M 22 X 1.5	630	630	
	DBU - 16S	16	30	32	32	50	35	31.5	16.5	M 24 X 1.5	630	400	250
	DBU - 20S	20	36	41	41	55	39	33.5	17.5	M 30 X 2.0	420	400	250
	DBU - 25S	25	46	46	46	59	44	35.0	20.0	M 36 X 2.0	420	400	250
	DBU - 30S	30	50	50	50	64	48	37.5	21.5	M 42 X 2.0	420	400	250
DBU - 38S	38	60	65	65	68	53	37.0	22.0	M 52 X 2.0	420	315		

## Welding Bulkhead Union DBUW

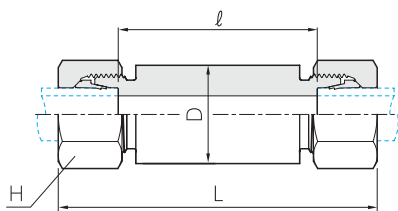

Series	Part No.	Tube O.D.	D	H	L	ℓ	PN(bar)	
							C.Steel	SS316
L	DBUW - 06L	6	18	14	85	56	500	315
	DBUW - 08L	8	20	17	85	56	500	315
	DBUW - 10L	10	22	19	87	58	500	315
	DBUW - 12L	12	25	22	87	58	400	315
	DBUW - 15L	15	28	27	100	70	400	315
	DBUW - 18L	18	32	32	101	69	400	315
	DBUW - 22L	22	36	36	105	73	250	160
	DBUW - 28L	28	40	41	106	73	250	160
	DBUW - 35L	35	50	50	114	71	250	160
DBUW - 42L	42	60	60	115	70	250	160	
S	DBUW - 06S	6	20	17	89	60	800	630
	DBUW - 08S	8	22	19	89	60	800	630
	DBUW - 10S	10	25	22	91	59	800	630
	DBUW - 12S	12	28	24	91	59	630	630
	DBUW - 14S	14	30	27	107	72	630	630
	DBUW - 16S	16	35	30	107	71	630	400
	DBUW - 20S	20	38	36	114	71	420	400
	DBUW - 25S	25	45	46	120	72	420	400
	DBUW - 30S	30	50	50	126	73	420	400
DBUW - 38S	38	60	60	133	72	420	315	

Dimensions are given for approximate length with tightened nut. All dimensions are in millimeters for reference only, subject to change.

Bulkhead Union Elbow  
**DBL**

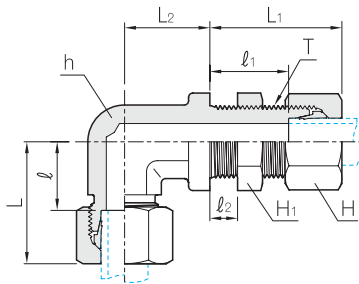

$l_2 = 16\text{mm Max.}$   
 $= 3\text{mm Min (06-18L and 06-16S)}$   
 $= 4\text{mm Min (22-42L and 20-38S)}$

Series	Part No.	Tube O.D.	H	H <sub>1</sub>	h	L	L <sub>1</sub>	L <sub>2</sub>	ℓ	ℓ <sub>1</sub>	T	PN(bar)		
												C.Steel	SS316	BRASS
L	DBL-06L	6	14	17	12	27	42	14	12.0	27.0	M 12 X 1.5	315	315	200
	DBL-08L	8	17	19	12	29	42	17	14.0	27.0	M 14 X 1.5	315	315	200
	DBL-10L	10	19	22	14	30	43	18	15.0	28.0	M 16 X 1.5	315	315	200
	DBL-12L	12	22	24	17	32	44	20	17.0	29.0	M 18 X 1.5	315	315	200
	DBL-15L	15	27	30	19	36	46	23	21.0	31.0	M 22 X 1.5	315	315	200
	DBL-18L	18	32	36	24	40	49	24	23.5	32.5	M 26 X 1.5	315	315	200
	DBL-22L	22	36	41	27	44	51	30	27.5	34.5	M 30 X 2	160	160	
	DBL-28L	28	41	46	36	47	52	34	30.5	35.5	M 36 X 2	160	160	
	DBL-35L	35	50	55	41	56	58	39	34.5	36.5	M 45 X 2	160	160	
DBL-42L	42	60	65	50	63	59	43	40.0	36.0	M 52 X 2	160	160		
S	DBL-06S	6	17	19	12	31	44	17	16.0	29.0	M 14 X 1.5	630	630	
	DBL-08S	8	19	22	14	32	44	18	17.0	29.0	M 16 X 1.5	630	630	
	DBL-10S	10	22	24	17	34	46	20	17.5	29.5	M 18 X 1.5	630	630	
	DBL-12S	12	24	27	17	38	47	21	21.5	30.5	M 20 X 1.5	630	630	
	DBL-14S	14	27	30	19	40	50	23	22.0	32.0	M 22 X 1.5	630	630	
	DBL-16S	16	30	32	24	43	50	24	24.5	31.5	M 24 X 1.5	400	400	
	DBL-20S	20	36	41	27	48	55	30	26.5	33.5	M 30 X 2	400	400	
	DBL-25S	25	46	46	36	54	59	34	30.0	35.0	M 36 X 2	400	400	
	DBL-30S	30	50	50	41	62	64	39	35.5	37.5	M 42 X 2	400	400	
DBL-38S	38	60	65	50	72	68	43	41.0	37.0	M 52 X 2	315	315		

Dimensions are given for approximate length with tightened nut. All dimensions are in millimeters for reference only, subject to change.

# Male Connector(Unified and Metric Parallel) with \*O-Ring DOM-U/M

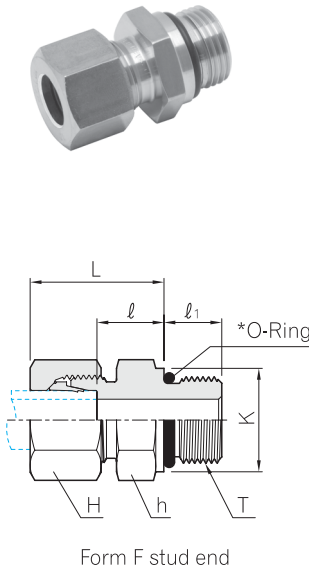

for Unified

Series	Part No.	Tube O.D.	H	h	K	L	l <sub>1</sub>	l	T	PN(bar)	
										C.Steel	SS316
L	DOM 08L-04U	8	17	17	14.4	25	9.0	10.0	7/16-20 UNF-2A	315	315
	DOM 10L-04U	10	19	17	14.4	26	10.0	11.0	7/16-20 UNF-2A	315	315
	DOM 12L-06U	12	22	19	17.6	26	10.0	11.0	9/16-18 UNF-2A	315	315
	DOM 12L-08U	12	22	24	22.3	28	11.0	13.0	3/4-16 UNF-2A	315	315
	DOM 12L-10U	12	22	27	25.5	29	12.7	14.3	7/8-14 UNF-2A	315	315
	DOM 15L-08U	15	27	24	22.3	29	11.0	14.0	3/4-16 UNF-2A	315	315
	DOM 15L-10U	15	27	27	25.5	30	12.7	15.3	7/8-14 UNF-2A	315	315
	DOM 18L-08U	18	32	27	22.3	31	11.0	14.5	3/4-16 UNF-2A	315	315
	DOM 18L-10U	18	32	27	25.5	31	12.7	14.8	7/8-14 UNF-2A	315	315
	DOM 22L-10U	22	36	32	25.5	33	12.7	16.8	7/8-14 UNF-2A	160	160
	DOM 22L-12U	22	36	32	31.9	33	15.0	16.5	1 1/16-12 UN-2A	160	160
	DOM 22L-16U	22	36	41	38.2	34	15.0	17.5	1 5/16-12 UN-2A	160	160
	DOM 28L-12U	28	41	41	31.9	34	15.0	17.5	1 1/16-12 UN-2A	160	160
	DOM 28L-16U	28	41	41	38.2	34	15.0	17.5	1 5/16-12 UN-2A	160	160
	DOM 35L-16U	35	50	46	38.2	39	15.0	17.5	1 5/16-12 UN-2A	160	160
	DOM 35L-20U	35	50	50	47.7	39	15.0	17.5	1 5/8-12 UN-2A	160	160
	DOM 42L-20U	42	60	55	47.7	42	15.0	19.0	1 5/8-12 UN-2A	160	160
	S	DOM 08S-04U	8	19	17	16.0	30	9.0	15.0	7/16-20 UNF-2A	630
DOM 10S-06U		10	22	19	17.6	31	10.0	14.5	9/16-18 UNF-2A	630	630
DOM 12S-06U		12	24	22	17.6	31	10.0	14.5	9/16-18 UNF-2A	630	630
DOM 12S-08U		12	24	24	22.3	34	11.0	17.5	3/4-16 UNF-2A	630	630
DOM 16S-08U		16	30	24	22.3	34	11.0	15.5	3/4-16 UNF-2A	400	400
DOM 16S-10U		16	30	27	25.5	37	12.7	18.8	7/8-14 UNF-2A	400	400
DOM 20S-08U		20	36	32	22.3	42	11.0	20.5	3/4-16 UNF-2A	400	400
DOM 20S-10U		20	36	32	25.5	42	12.7	20.8	7/8-14 UNF-2A	400	400
DOM 20S-12U		20	36	32	31.9	42	15.0	20.5	1 1/16-12 UN-2A	400	400
DOM 25S-12U		25	46	36	31.9	47	15.0	23.0	1 1/16-12 UN-2A	400	400
DOM 25S-16U		25	46	41	38.2	47	15.0	23.0	1 5/16-12 UN-2A	400	400
DOM 30S-16U		30	50	46	38.2	50	15.0	23.5	1 5/16-12 UN-2A	400	400
DOM 30S-20U		30	50	50	47.7	50	15.0	23.5	1 5/8-12 UN-2A	400	400
DOM 38S-20U		38	60	55	47.7	57	15.0	26.0	1 5/8-12 UN-2A	315	315

for Metric Parallel

Series	Part No.	Tube O.D.	H	h	K	L	l <sub>1</sub>	l	T
L	DOM 06L-M10	6	14	14	-	23	10.0	8.5	M 10 x 1.0
	DOM 08L-M12	8	17	17	-	25	11.5	10.0	M 12 x 1.5
	DOM 10L-M14	10	19	19	-	26	11.5	11.0	M 14 x 1.5
	DOM 12L-M16	12	22	22	-	27	13.0	12.0	M 16 x 1.5
	DOM 15L-M18	15	27	24	-	29	14.5	13.5	M 18 x 1.5
	DOM 18L-M22	18	32	27	-	30	15.5	14.0	M 22 x 1.5
	DOM 22L-M26	22	36	32	-	32	16.0	16.0	M 26 x 1.5
	DOM 28L-M33	28	41	41	38	34	19.0	17.5	M 33 x 2.0
DOM 35L-M42	35	50	50	48	39	19.5	17.5	M 42 x 2.0	
S	DOM 06S-M12	6	17	17	-	27	11.5	12.0	M 12 x 1.5
	DOM 08S-M14	8	19	19	-	27	11.5	12.0	M 14 x 1.5
	DOM 10S-M16	10	22	22	-	29	13.0	12.5	M 16 x 1.5
	DOM 12S-M18	12	24	24	-	29	14.5	13.0	M 18 x 1.5
	DOM 16S-M22	16	30	27	-	33	15.5	15.0	M 22 x 1.5
	DOM 20S-M27	20	36	32	-	37	19.0	15.0	M 27 x 2.0
	DOM 25S-M33	25	46	41	38	41	19.0	17.0	M 33 x 2.0
DOM 30S-M42	30	50	50	48	45	19.5	18.5	M 42 x 2.0	

Dimensions are given for approximate length with tightened nut, All dimensions are in millimeters for reference only, subject to change.  
\* The standard O-Ring material is NBR(e.g. Perbunan®) however FPM(e.g. Viton®) is also available on request (See Page 3).

## 24° Tube Fittings-DIN 2353 & ISO 8434-1

### Male Connector (ISO/BSP Parallel) DMC-G

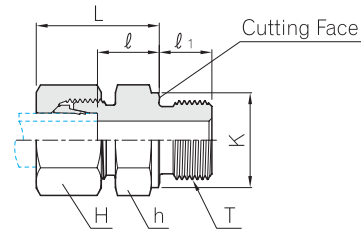

Form B stud end

Series	Part No.	Tube O.D.	H	h	K	L	l	l <sub>1</sub>	T	PN(bar)		
										C.Steel	SS316	BRASS
L	DMC 06L - 01G	6	14	14	14	23.0	8.5	8	G 1/8	315	315	200
	DMC 06L - 02G	6	14	19	18	25.0	10.0	12	G 1/4	315	315	200
	DMC 06L - 03G	6	14	22	22	26.0	11.5	12	G 3/8	315	315	200
	DMC 06L - 04G	6	14	27	26	27.0	12.0	14	G 1/2	315	315	
	DMC 08L - 01G	8	17	14	14	23.0	8.5	8	G 1/8	315	315	
	DMC 08L - 02G	8	17	19	18	25.0	10.0	12	G 1/4	315	315	200
	DMC 08L - 03G	8	17	22	22	26.0	11.5	12	G 3/8	315	315	200
	DMC 08L - 04G	8	17	27	26	27.0	12.0	14	G 1/2	315	315	200
	DMC 10L - 02G	10	19	19	18	26.0	11.0	12	G 1/4	315	315	200
	DMC 10L - 03G	10	19	22	22	27.0	12.5	12	G 3/8	315	315	200
	DMC 10L - 04G	10	19	27	26	28.0	13.0	14	G 1/2	315	315	200
	DMC 12L - 02G	12	22	19	18	27.0	12.0	12	G 1/4	315	315	200
	DMC 12L - 03G	12	22	22	22	27.0	12.5	12	G 3/8	315	315	200
	DMC 12L - 04G	12	22	27	26	28.0	13.0	14	G 1/2	315	315	200
	DMC 12L - 06G	12	22	32	32	29.0	14.0	16	G 3/4	315	315	
	DMC 15L - 03G	15	27	24	22	29.0	13.5	12	G 3/8	250	250	160
	DMC 15L - 04G	15	27	27	26	29.0	14.0	14	G 1/2	250	250	160
	DMC 15L - 06G	15	27	32	32	30.0	15.0	16	G 3/4	250	250	
	DMC 18L - 03G	18	32	27	22	29.5	14.0	12	G 3/8	250	250	
	DMC 18L - 04G	18	32	27	26	31.0	14.5	14	G 1/2	250	250	160
	DMC 18L - 06G	18	32	32	32	30.0	14.5	16	G 3/4	250	250	
	DMC 22L - 04G	22	36	32	26	33.0	16.5	14	G 1/2	160	160	100
	DMC 22L - 06G	22	36	32	32	33.0	16.5	16	G 3/4	160	160	100
	DMC 28L - 06G	28	41	41	32	34.0	17.5	16	G 3/4	160	160	
DMC 28L - 08G	28	41	41	39	34.0	17.5	18	G 1	160	160	100	
DMC 35L - 08G	35	50	46	39	39.0	17.5	18	G 1	160	160		
DMC 35L - 10G	35	50	50	49	39.0	17.5	20	G 1 1/4	160	160	100	
DMC 42L - 12G	42	60	55	55	42.0	19.0	22	G 1 1/2	160	160	100	
S	DMC 06S - 02G	6	17	19	18	28.0	13.0	12	G 1/4	400	400	250
	DMC 06S - 04G	6	17	27	26	33.0	18.0	14	G 1/2	400	400	
	DMC 08S - 02G	8	19	19	18	30.0	15.0	12	G 1/4	400	400	250
	DMC 08S - 03G	8	19	22	22	30.0	15.5	12	G 3/8	400	400	
	DMC 10S - 02G	10	22	19	18	31.0	14.5	12	G 1/4	400	400	
	DMC 10S - 03G	10	22	22	22	31.0	15.0	12	G 3/5	400	400	250
	DMC 10S - 04G	10	22	27	26	34.0	17.5	14	G 1/2	400	400	
	DMC 12S - 02G	12	24	22	18	33.0	16.5	12	G 1/4	400	400	
	DMC 12S - 03G	12	24	22	22	33.0	17.0	12	G 3/8	400	400	250
	DMC 12S - 04G	12	24	27	26	34.0	17.5	14	G 1/2	400	400	
	DMC 14S - 03G	14	27	24	22	36.0	18.5	12	G 3/8	400	400	
	DMC 14S - 04G	14	27	27	26	37.0	19.0	14	G 1/2	400	400	250
	DMC 16S - 03G	16	30	27	22	36.0	18.0	12	G 3/8	400	400	
	DMC 16S - 04G	16	30	27	26	37.0	18.5	14	G 1/2	400	400	250
	DMC 16S - 06G	16	30	32	32	39.0	20.5	16	G 3/4	400	400	
	DMC 20S - 04G	20	36	32	26	42.0	20.5	14	G 1/2	400	400	
	DMC 20S - 06G	20	36	32	32	42.0	20.5	16	G 3/4	400	400	250
	DMC 25S - 06G	25	46	41	32	47.0	23.0	16	G 3/4	250	250	160
	DMC 25S - 08G	25	46	41	39	47.0	23.0	18	G 1	250	250	
	DMC 30S - 08G	30	50	46	39	50.0	23.5	18	G 1	160	160	
	DMC 30S - 10G	30	50	50	49	50.0	23.5	20	G 1 1/4	160	160	100
	DMC 38S - 10G	38	60	55	49	57.0	26.0	20	G 1 1/4	160	160	
	DMC 38S - 12G	38	60	55	55	57.0	26.0	22	G 1 1/2	160	160	100

Dimensions are given for approximate length with tightened nut. All dimensions are in millimeters for reference only, subject to change.

Male Connector (ISO/BSP Tapered)  
**DMC-R**

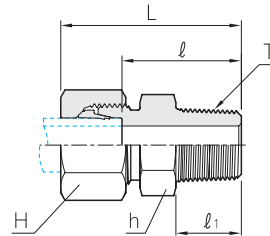

Form C stud end

Series	Part No.	Tube O.D.	H	h	K	L	l	l <sub>1</sub>	T	PN(bar)		
										C.Steel	SS316	BRASS
LL	DMC 04LL - 01R	4	10	11	-	26	16.0	8	R 1/8	100	100	63
	DMC 06LL - 01R	6	12	11	-	26	14.5	8	R 1/8	100	100	63
	DMC 08LL - 01R	8	14	12	-	28	16.5	8	R 1/8	100	100	63
	DMC 08LL - 02R	8	14	14	-	32	20.5	12	R 1/4	100	100	63
	DMC 10LL - 02R	10	17	14	-	32	20.5	12	R 1/4	100		63
	DMC 12LL - 02R	12	19	17	-	32	20.0	12	R 1/4	100		63
	DMC 12LL - 03R	12	19	17	-	32	20.0	12	R 3/8	100		63
L	DMC 06L - 01R	6	14	12	-	30	15.0	8	R 1/8	315	315	
	DMC 08L - 02R	8	17	17	-	35	20.0	12	R 1/4	315	315	
	DMC 10L - 02R	10	19	17	-	36	21.0	12	R 1/4	315	315	
	DMC 12L - 02R	12	22	19	-	37	22.0	12	R 1/4	315		200
	DMC 12L - 03R	12	22	19	-	37	22.0	12	R 3/8	315	315	
	DMC 12L - 04R	12	22	24	-	39	24.0	14	R 1/2	315	315	200
	DMC 15L - 03R	15	27	24	-	38	23.0	12	R 3/8	315	250	200
	DMC 15L - 04R	15	27	24	-	40	25.0	14	R 1/2	315	315	
	DMC 18L - 04R	18	32	27	-	41	25.5	14	R 1/2	315	250	100
DMC 22L - 06R	22	36	32	-	46	29.5	16	R 3/4	160	160	100	

Dimensions are given for approximate length with tightened nut. All dimensions are in millimeters for reference only, subject to change.

## 24° Tube Fittings-DIN 2353 & ISO 8434-1

### Male Connector (Metric Tapered) DMC-MK

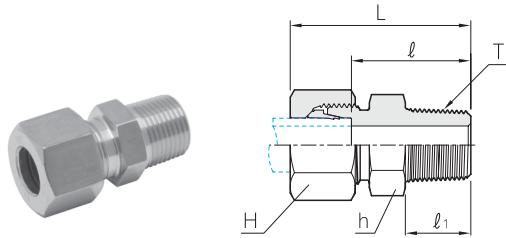

Form C stud end

### Male Connector (Metric Parallel) DMC-M

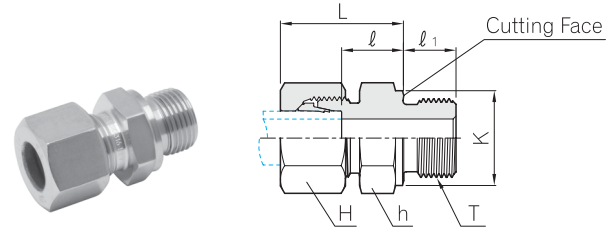

Form B stud end

Series	Part No.	Tube O.D.	H	h	K	L	l	l <sub>1</sub>	T	PN(bar)		
										C.Steel	SS316	BRASS
LL	DMC 04LL - M 6K	4	10	9	-	26	16.0	8	M 6 x 1Keg	100		
	DMC 04LL - M 8K	4	10	10	-	26	16.0	8	M 8 x 1Keg	100	100	63
	DMC 06LL - M10K	6	12	11	-	26	14.5	8	M 10 x 1Keg	100	100	63
	DMC 08LL - M10K	8	14	12	-	28	16.5	8	M 10 x 1Keg	100	100	63
L	DMC 06L - M10	6	14	14	14	23	8.5	8	M 10 x 1.0	315	315	200
	DMC 08L - M12	8	17	17	17	25	10.0	12	M 12 x 1.5	315	315	200
	DMC 08L - M18	8	17	24	23	26	11.5	12	M 18 x 1.5	315	315	
	DMC 10L - M14	10	19	19	19	26	11.0	12	M 14 x 1.5	315	315	200
	DMC 10L - M16	10	19	22	21	27	12.0	12	M 16 x 1.5	315	315	
	DMC 10L - M18	10	19	24	23	27	12.5	12	M 18 x 1.5	315	315	
	DMC 10L - M22	10	19	27	27	29	14.0	14	M 22 x 1.5	315	315	
	DMC 12L - M14	12	22	19	19	26	11.0	12	M 14 x 1.5	315	315	
	DMC 12L - M16	12	22	22	21	27	12.5	12	M 16 x 1.5	315	315	
	DMC 12L - M18	12	22	24	23	27	12.5	12	M 18 x 1.5	315	315	
	DMC 12L - M22	12	22	27	27	29	14.0	14	M 22 x 1.5	315	315	
	DMC 15L - M16	15	27	24	21	28	13.0	12	M 16 x 1.5	250	250	
	DMC 15L - M18	15	27	24	23	29	13.5	12	M 18 x 1.5	250	250	100
	DMC 15L - M22	15	27	27	27	30	15.0	14	M 22 x 1.5	250	250	
	DMC 18L - M18	18	32	27	23	30	14.0	12	M 18 x 1.5	250	250	
	DMC 18L - M22	18	32	27	27	31	14.5	14	M 22 x 1.5	250	250	160
	DMC 22L - M22	22	36	32	27	33	16.5	14	M 22 x 1.5	160	160	
	DMC 22L - M26	22	36	32	31	33	16.5	16	M 26 x 1.5	160	160	100
	DMC 28L - M33	28	41	41	39	34	17.5	18	M 33 x 2.0	160	160	100
	DMC 35L - M42	35	50	50	49	39	17.5	20	M 42 x 2.0	160	160	100
DMC 42L - M48	42	60	55	55	42	19.0	22	M 48 x 2.0	160	160	100	
S	DMC 06S - M12	6	17	17	17	28	13.0	12	M 12 x 1.5	400	400	250
	DMC 08S - M14	8	19	19	19	30	15.0	12	M 14 x 1.5	400	400	250
	DMC 10S - M16	10	22	22	21	31	15.0	12	M 16 x 1.5	400	400	250
	DMC 12S - M18	12	24	24	23	33	17.0	12	M 18 x 1.5	400	400	250
	DMC 12S - M22	12	24	27	27	34	17.5	14	M 22 x 1.5	400	400	
	DMC 14S - M20	14	27	27	25	37	19.0	14	M 20 x 1.5	400	400	250
	DMC 16S - M18	16	30	27	23	36	18.0	12	M 18 x 1.5	400	400	
	DMC 16S - M22	16	30	27	27	37	18.5	14	M 22 x 1.5	400	400	250
	DMC 20S - M27	20	36	32	32	42	20.5	16	M 27 x 2.0	400	400	250
	DMC 25S - M33	25	46	41	39	47	23.0	18	M 33 x 2.0	250	250	160
	DMC 30S - M42	30	50	50	49	50	23.5	20	M 42 x 2.0	160	160	100
	DMC 38S - M48	38	60	55	55	57	26.0	22	M 48 x 2.0	160	160	100

Dimensions are given for approximate length with tightened nut. All dimensions are in millimeters for reference only, subject to change.



# Male Connector(ISO/BSP Parallel) with \*ED-Ring DMC-GED

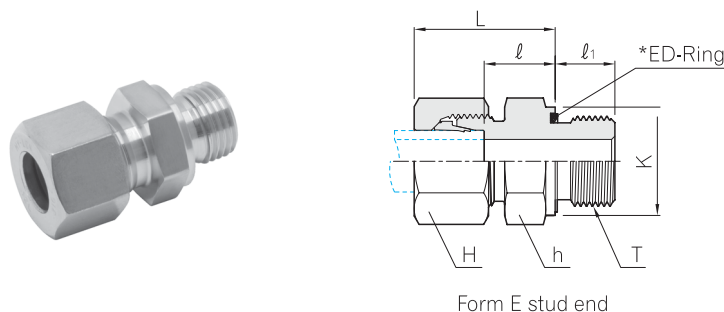

Series	Part No.	Tube O.D.	H	h	K	L	l	l <sub>1</sub>	T	PN(bar)		
										C.Steel	SS316	BRASS
L	DMC 06L - 01GED	6	14	14	14	23	8,5	8	G 1/8	500	315	200
	DMC 06L - 02GED	6	14	19	19	25	10.0	12	G 1/4	500	315	200
	DMC 08L - 01GED	8	17	14	14	24	9.5	8	G 1/8	500	315	200
	DMC 08L - 02GED	8	17	19	19	25	10.0	12	G 1/4	500	315	200
	DMC 08L - 03GED	8	17	22	22	26	11.5	12	G 3/8	420	315	200
	DMC 10L - 02GED	10	19	19	19	26	11.0	12	G 1/4	500	315	200
	DMC 10L - 03GED	10	19	22	22	27	12.5	12	G 3/8	420	315	200
	DMC 10L - 04GED	10	19	27	27	28	13.0	14	G 1/2	400	315	200
	DMC 12L - 02GED	12	22	19	19	27	12.0	12	G 1/4	400	315	200
	DMC 12L - 03GED	12	22	22	22	27	12.5	12	G 3/8	420	315	200
	DMC 12L - 04GED	12	22	27	27	28	13.0	14	G 1/2	400	315	200
	DMC 15L - 03GED	15	27	24	22	29	13.5	12	G 3/8	400	315	200
	DMC 15L - 04GED	15	27	27	27	29	14.0	14	G 1/2	400	315	200
	DMC 18L - 04GED	18	32	27	27	31	14.5	14	G 1/2	400	315	200
	DMC 18L - 06GED	18	32	32	32	31	14.5	16	G 3/4	250	160	100
	DMC 22L - 06GED	22	36	32	32	33	16.5	16	G 3/4	250	160	100
	DMC 28L - 08GED	28	41	41	40	34	17.5	18	G 1	250	160	100
	DMC 35L - 10GED	35	50	50	50	39	17.5	20	G 1 1/4	250	160	100
DMC 42L - 12GED	42	60	55	55	42	19.0	22	G 1 1/2	250	160	100	
S	DMC 06S - 02GED	6	17	19	19	28	13.0	12	G 1/4	800	630	400
	DMC 08S - 02GED	8	19	19	19	30	15.0	12	G 1/4	800	630	400
	DMC 08S - 03GED	8	19	22	22	30	15.5	12	G 3/8	800	630	
	DMC 10S - 02GED	10	22	19	19	31	14.5	12	G 1/4	800	630	
	DMC 10S - 03GED	10	22	22	22	31	15.0	12	G 3/8	800	630	400
	DMC 10S - 04GED	10	22	27	27	34	17.5	14	G 1/2	630	630	
	DMC 12S - 02GED	12	24	22	19	33	16.5	12	G 1/4	630	630	
	DMC 12S - 03GED	12	24	22	22	33	17.0	12	G 3/8	630	630	400
	DMC 12S - 04GED	12	24	27	32	34	17.5	14	G 1/2	630	630	
	DMC 14S - 04GED	14	27	27	27	37	19.0	14	G 1/2	630	630	400
	DMC 16S - 03GED	16	30	27	22	36	18.0	12	G 3/8	630	400	
	DMC 16S - 04GED	16	30	27	27	37	18.5	14	G 1/2	630	400	250
	DMC 16S - 06GED	16	30	32	27	39	20.5	16	G 3/4	420	400	
	DMC 20S - 06GED	20	36	32	32	42	20.5	16	G 3/4	420	400	250
	DMC 25S - 04GED	25	46	41	27	47	23.0	14	G 1/2	420	400	
	DMC 25S - 06GED	25	46	41	32	47	23.0	16	G 3/4	420	400	
	DMC 25S - 08GED	25	46	41	40	47	23.0	18	G 1	420	400	250
	DMC 30S - 10GED	30	50	50	50	50	23.5	20	G 1 1/4	420	400	250
DMC 38S - 12GED	38	60	55	55	57	26.0	22	G 1 1/2	420	315	200	

Dimensions given for approximate length with tightened nut. All dimensions are in millimeters for reference only, subject to change.  
\* The standard ED-Ring material is NBR(e.g. perbunan®) however FPM(e.g. Viton®) is also available on Request (See Page3).

## 24° Tube Fittings-DIN 2353 & ISO 8434-1

### Male Connector(Metric Parallel) with \*ED-Ring DMC-MED

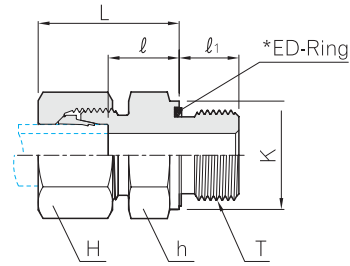
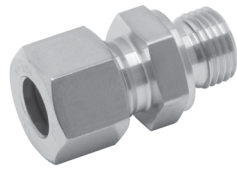

Form E stud end

Series	Part No.	Tube O.D.	H	h	K	L	l	l <sub>1</sub>	T	PN(bar)	
										C.Steel	SS316
L	DMC 06L - M10ED	6	14	14	14	23	8.5	8	M 10 x 1.0	500	315
	DMC 08L - M12ED	8	17	17	17	25	10.0	12	M 12 x 1.5	500	315
	DMC 10L - M14ED	10	19	19	19	26	11.0	12	M 14 x 1.5	500	315
	DMC 12L - M16ED	12	22	22	22	27	12.5	12	M 16 x 1.5	400	315
	DMC 12L - M18ED	12	22	24	24	27	12.5	12	M 18 x 1.5	400	315
	DMC 12L - M22ED	12	22	27	27	29	14.0	14	M 22 x 1.5	400	315
	DMC 15L - M18ED	15	27	24	24	29	13.5	12	M 18 x 1.5	400	315
	DMC 15L - M22ED	15	27	27	27	30	15.0	14	M 22 x 1.5	400	315
	DMC 18L - M22ED	18	32	27	27	31	14.5	14	M 22 x 1.5	400	315
	DMC 22L - M26ED	22	36	32	32	33	16.5	16	M 26 x 1.5	250	160
	DMC 28L - M33ED	28	41	41	40	34	17.5	18	M 33 x 2.0	250	160
	DMC 35L - M42ED	35	50	50	50	39	17.5	20	M 42 x 2.0	250	160
DMC 42L - M48ED	42	60	55	55	42	19.0	22	M 48 x 2.0	250	160	
S	DMC 06S - M12ED	6	17	17	17	28	13.0	12	M 12 x 1.5	800	630
	DMC 08S - M14ED	8	19	19	19	30	15.0	12	M 14 x 1.5	800	630
	DMC 10S - M16ED	10	22	22	22	31	15.0	12	M 16 x 1.5	800	630
	DMC 12S - M18ED	12	24	24	24	33	17.0	12	M 18 x 1.5	630	630
	DMC 14S - M20ED	14	27	27	26	37	19.0	14	M 20 x 1.5	630	630
	DMC 16S - M22ED	16	30	27	27	37	18.5	14	M 22 x 1.5	630	400
	DMC 20S - M27ED	20	36	32	32	42	20.5	16	M 27 x 2.0	420	400
	DMC 25S - M33ED	25	46	41	40	47	23.0	18	M 33 x 2.0	420	400
	DMC 30S - M42ED	30	50	50	50	50	23.5	20	M 42 x 2.0	420	400
	DMC 38S - M48ED	38	60	55	55	57	26.0	22	M 48 x 2.0	420	315

Dimensions given for approximate length with tightened nut. All dimensions are in millimeters for reference only, subject to change.

\* The standard ED-Ring material is NBR(e.g. perbunan®) however FPM(e.g. Viton®) is also available on Request (See Page3).

Male Connector (NPT Tapered)  
**DMC-N**

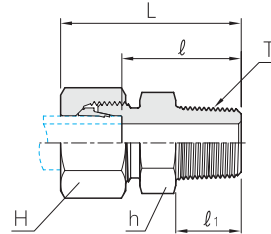
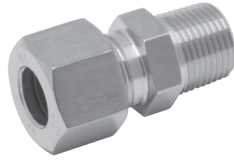

Form C stud end

Series	Part No.	Tube O.D.	H	h	L	l	l <sub>1</sub>	T	PN(bar)		
									C.Steel	SS316	BRASS
LL	DMC 04LL - 01N	4	10	11	28	18.5	9.9	1/8 - 27.0 NPT	100	100	
	DMC 06LL - 01N	6	12	11	28	16.5	9.9	1/8 - 27.0 NPT	100	100	63
	DMC 08LL - 01N	8	14	12	30	18.5	9.9	1/8 - 27.0 NPT	100	100	63
L	DMC 06L - 01N	6	14	12	32	17.0	9.9	1/8 - 27.0 NPT	315	315	200
	DMC 06L - 02N	6	14	17	38	23.0	14.2	1/4 - 18.0 NPT	315	315	200
	DMC 08L - 02N	8	17	17	38	23.0	14.2	1/4 - 18.0 NPT	315	315	200
	DMC 10L - 02N	10	19	17	39	24.0	14.2	1/4 - 18.0 NPT	315	315	200
	DMC 10L - 03N	10	19	19	40	25.0	14.2	3/8 - 18.0 NPT	315	315	
	DMC 12L - 02N	12	22	19	40	25.0	14.2	1/4 - 18.0 NPT	315	315	200
	DMC 12L - 03N	12	22	19	40	25.0	14.2	3/8 - 18.0 NPT	315	315	200
	DMC 12L - 04N	12	22	22	45	30.0	19.1	1/2 - 14.0 NPT	315	315	200
	DMC 15L - 04N	15	27	24	46	31.0	19.1	1/2 - 14.0 NPT	315	315	200
	DMC 18L - 04N	18	32	27	48	31.5	19.1	1/2 - 14.0 NPT	315	315	200
	DMC 22L - 06N	22	36	32	50	33.5	19.1	3/4 - 14.0 NPT	160	160	100
	DMC 28L - 08N	28	41	41	56	39.5	23.9	1 - 11.5 NPT	160	160	100
	DMC 35L - 10N	35	50	46	62	40.5	23.9	1 1/4 - 11.5 NPT	160	160	
DMC 42L - 12N	42	60	55	65	42.0	25.4	1 1/2 - 11.5 NPT	160	160		
S	DMC 06S - 02N	6	17	17	43	28.0	14.2	1/4 - 18.0 NPT	630	630	400
	DMC 08S - 02N	8	19	17	43	28.0	14.2	1/4 - 18.0 NPT	630	630	400
	DMC 10S - 02N	10	22	19	44	27.5	14.2	1/4 - 18.0 NPT	630	630	
	DMC 10S - 03N	10	22	19	44	27.5	14.2	3/8 - 18.0 NPT	630	630	400
	DMC 12S - 02N	12	24	22	46	29.5	14.2	1/4 - 18.0 NPT	630	630	
	DMC 12S - 03N	12	24	22	46	29.5	14.2	3/8 - 18.0 NPT	630	630	400
	DMC 12S - 04N	12	24	22	51	34.5	19.1	1/2 - 14.0 NPT	630	630	400
	DMC 14S - 04N	14	27	24	54	36.0	19.1	1/2 - 14.0 NPT	630	630	400
	DMC 16S - 04N	16	30	27	54	35.5	19.1	1/2 - 14.0 NPT	400	400	250
	DMC 20S - 06N	20	36	32	59	37.5	19.1	3/4 - 14.0 NPT	400	400	250
	DMC 25S - 08N	25	46	41	69	45.0	23.9	1 - 11.5 NPT	400	400	
	DMC 30S - 10N	30	50	46	73	46.5	23.9	1 1/4 - 11.5 NPT	400	400	
DMC 38S - 12N	38	60	55	80	49.0	25.4	1 1/2 - 11.5 NPT	315	315		

Dimensions are given for approximate length with tightened nut. All dimensions are in millimeters for reference only, subject to change.

Male Elbow (ISO/BSP Tapered / Metric Tapered)

**DLM-R/M**

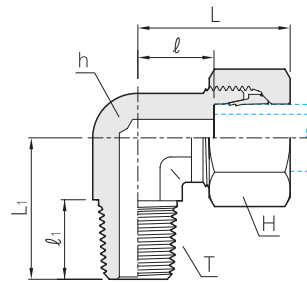

Form C stud end

for ISO/BSP Tapered

Series	Part No.	Tube O.D.	H	h	L	L <sub>1</sub>	ℓ	ℓ <sub>1</sub>	T	PN(bar)		
										C.Steel	SS316	BRASS
LL	DLM 04LL - 01R	4	10	9	21	17	11.0	10	R 1/8	100	100	63
	DLM 06LL - 01R	6	12	9	21	17	9.5	10	R 1/8	100	100	63
	DLM 08LL - 01R	8	14	12	23	20	11.5	10	R 1/8	100	100	63
	DLM 10LL - 02R	10	17	14	24	23	12.5	14	R 1/4	100		
	DLM 12LL - 02R	12	19	17	25	23	13.0	14	R 1/4	100		
L	DLM 06L - 01R	6	14	12	27	20	12.0	10	R 1/8	315	315	200
	DLM 08L - 02R	8	17	12	29	26	14.0	14	R 1/4	315	315	200
	DLM 10L - 02R	10	19	14	30	27	15.0	14	R 1/4	315	315	200
	DLM 12L - 03R	12	22	17	32	28	17.0	15	R 3/8	315	315	200
	DLM 15L - 04R	15	27	19	36	34	21.0	19	R 1/2	315	315	200
	DLM 18L - 04R	18	32	24	40	36	23.5	19	R 1/2	315	315	200
S	DLM 06S - 02R	6	17	12	31	26	16.0	14	R 1/4	400	400	250
	DLM 08S - 02R	8	19	14	32	27	17.0	14	R 1/4	400	400	250
	DLM 10S - 03R	10	22	17	34	28	17.5	15	R 3/8	400	400	250
	DLM 12S - 03R	12	24	17	38	28	21.5	15	R 3/8	400	400	250
	DLM 14S - 04R	14	27	19	40	32	22.0	19	R 1/2	400	400	
	DLM 16S - 04R	16	30	24	43	32	24.5	19	R 1/2	400	400	250

for Metric Tapered

Series	Part No.	Tube O.D.	H	h	L	L <sub>1</sub>	ℓ	ℓ <sub>1</sub>	T	PN(bar)		
										C.Steel	SS316	BRASS
LL	DLM 04LL - M 8K	4	10	9	21	17	11.0	8	M 8 x 1.0	100	100	63
	DLM 06LL - M10K	6	12	9	21	17	9.5	8	M10 x 1.0	100	100	63
	DLM 08LL - M10K	8	14	12	23	20	11.5	8	M10 x 1.0	100	100	63
L	DLM 06L - M10K	6	14	12	27	20	12.0	8	M10 x 1.0	315	315	200
	DLM 08L - M12K	8	17	12	29	26	14.0	12	M12 x 1.5	315	315	200
	DLM 10L - M14K	10	19	14	30	27	15.0	12	M14 x 1.5	315	315	200
	DLM 12L - M16K	12	22	17	32	28	17.0	14	M16 x 1.5	315	315	200
	DLM 15L - M18K	15	27	19	36	34	21.0	14	M18 x 1.5	315	315	200
	DLM 18L - M22K	18	32	24	40	36	23.5	17	M22 x 1.5	315	315	200
S	DLM 06S - M12K	6	17	12	31	26	16.0	12	M12 x 1.5	400	400	250
	DLM 08S - M14K	8	19	14	32	27	17.0	12	M14 x 1.5	400	400	250
	DLM 10S - M16K	10	22	17	34	28	17.5	12	M16 x 1.5	400	400	250
	DLM 12S - M18K	12	24	17	38	28	21.5	12	M18 x 1.5	400	400	250
	DLM 14S - M20K	14	27	19	40	32	22.0	14	M20 x 1.5	400	400	
	DLM 16S - M22K	16	30	24	43	32	24.5	17	M22 x 1.5	400	400	250

Dimensions are given for approximate length with tightened nut. All dimensions are in millimeters for reference only, subject to change.

Female Connector(ISO/BSP Parallel / Metric Parallel)

**DFC-G/M**

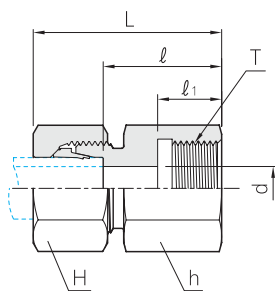
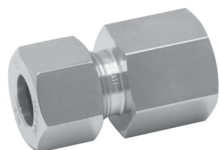

Form Y Tapped Hole

for ISO/BSP Parallel

Series	Part No.	Tube O.D.	d	H	h	L	ℓ	ℓ <sub>1</sub>	T	PN(bar)		
										C.Steel	SS316	BRASS
L	DFC 06L - 01G	6	4	14	14	34	19.0	12.0	G 1/8	315	315	200
	DFC 08L - 02G	8	6	17	19	39	24.0	17.0	G 1/4	315	315	200
	DFC 08L - 03G	8	6	17	24	40	25.0	17.0	G 3/8	315	315	200
	DFC 08L - 04G	8	6	17	27	44	29.0	20.0	G 1/2	315	315	200
	DFC 10L - 02G	10	8	19	19	40	25.0	17.0	G 1/4	315	315	200
	DFC 10L - 03G	10	8	19	24	41	26.0	17.0	G 3/8	315	315	200
	DFC 10L - 04G	10	8	19	27	45	30.0	20.0	G 1/2	315	315	200
	DFC 12L - 03G	12	10	22	24	41	26.0	17.0	G 3/8	315	315	200
	DFC 12L - 04G	12	10	22	27	45	30.0	20.0	G 1/2	315	315	200
	DFC 15L - 04G	15	12	27	27	46	31.0	20.0	G 1/2	315	315	200
	DFC 18L - 04G	18	15	32	27	47	30.5	20.0	G 1/2	315	315	200
	DFC 22L - 06G	22	19	36	36	52	35.5	22.0	G 3/4	160	160	100
	DFC 28L - 08G	28	24	41	41	55	38.0	24.5	G 1	160	160	100
	DFC 35L - 10G	35	30	50	55	63	41.0	26.5	G 1 1/4	160	160	100
DFC 42L - 12G	42	36	60	60	65	42.5	28.5	G 1 1/2	160	160	100	
S	DFC 06S - 02G	6	4	17	19	41	26.0	17.0	G 1/4	400	400	
	DFC 08S - 02G	8	5	19	19	41	26.0	17.0	G 1/4	400	400	
	DFC 10S - 03G	10	7	22	24	43	26.5	17.0	G 3/8	400	400	
	DFC 12S - 03G	12	8	24	24	43	26.5	17.0	G 3/8	400	400	
	DFC 14S - 04G	14	10	27	30	50	32.0	20.0	G 1/2	400	400	
	DFC 16S - 04G	16	12	30	30	50	31.5	20.0	G 1/2	400	400	
	DFC 20S - 06G	20	16	36	36	56	34.5	22.0	G 3/4	315	315	
	DFC 25S - 08G	25	20	46	41	62	37.5	24.5	G 1	315	315	
	DFC 30S - 10G	30	25	50	55	69	42.0	26.5	G 1 1/4	315	315	
	DFC 38S - 12G	38	32	60	60	74	43.5	28.5	G 1 1/2	250	250	

for Metric Parallel

Series	Part No.	Tube O.D.	d	H	h	L	ℓ	ℓ <sub>1</sub>	T	PN(bar)	
										C.Steel	SS316
L	DFC 06L - M10	6	4	14	14	34	19.5	12.5	M 10 x 1.0	315	315
	DFC 08L - M12	8	6	17	17	39	24.0	17.0	M 12 x 1.5	315	315
	DFC 10L - M14	10	8	19	19	40	25.0	17.0	M 14 x 1.5	315	315
	DFC 12L - M16	12	10	22	22	41	26.0	17.0	M 16 x 1.5	315	315
	DFC 15L - M18	15	12	27	24	43	28.0	17.0	M 18 x 1.5	315	315
	DFC 18L - M22	18	15	32	30	46	29.5	19.0	M 22 x 1.5	315	315
	DFC 22L - M26	22	19	36	32	51	34.5	21.0	M 26 x 1.5	160	160
	DFC 28L - M33	28	24	41	41	54	37.5	24.0	M 33 x 2.0	160	160
	DFC 35L - M42	35	30	50	55	62	40.5	26.0	M 42 x 2.0	160	160
	DFC 42L - M48	42	36	60	60	65	42.0	28.0	M 48 x 2.0	160	160
S	DFC 06S - M12	6	4	17	17	41	26.0	17.0	M 12 x 1.5	400	400
	DFC 08S - M14	8	5	19	19	41	26.0	17.0	M 14 x 1.5	400	400
	DFC 10S - M16	10	7	22	22	43	26.5	17.0	M 16 x 1.5	400	400
	DFC 12S - M18	12	8	24	24	44	27.5	17.0	M 18 x 1.5	400	400
	DFC 14S - M20	14	10	27	27	49	31.0	19.0	M 20 x 1.5	400	400
	DFC 16S - M22	16	12	30	30	49	30.5	19.0	M 22 x 1.5	400	400
	DFC 20S - M27	20	16	36	36	56	34.5	22.0	M 27 x 2.0	315	315
	DFC 25S - M33	25	20	46	41	61	37.0	24.0	M 33 x 2.0	315	315
	DFC 30S - M42	30	25	50	55	68	41.5	26.0	M 42 x 2.0	315	315
	DFC 38S - M48	38	32	60	60	74	43.0	28.0	M 48 x 2.0	250	250

Dimensions are given for approximate length with tightened nut. All dimensions are in millimeters for reference only, subject to change.

## 24° Tube Fittings-DIN 2353 & ISO 8434-1

### Adjustable Elbow with Standpipe

#### DLA

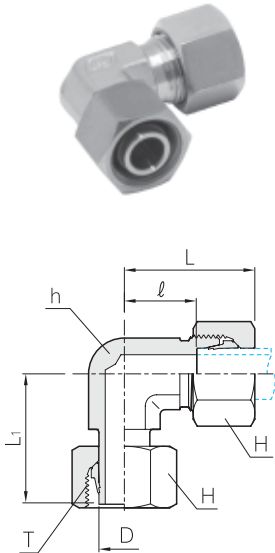

Series	Part No.	Tube O.D.	D	H <sub>1</sub>	h	L	L <sub>1</sub>	l	T			
L	DLA - 06L	6	6	14	12	27	26.0	12.0	M 12 x 1,5			
	DLA - 08L	8	8	17	12	29	27.5	14.0	M 14 x 1,5			
	DLA - 10L	10	10	19	14	30	29.0	15.0	M 16 x 1,5			
	DLA - 12L	12	12	22	17	32	29.5	17.0	M 18 x 1,5			
	DLA - 15L	15	15	27	19	36	32.5	21.0	M 22 x 1,5			
	DLA - 18L	18	18	32	24	40	35.5	23.5	M 26 x 1,5			
	DLA - 22L	22	22	36	27	44	38.5	27.5	M 30 x 2			
	DLA - 28L	28	28	41	36	47	41.5	30.5	M 36 x 2			
	DLA - 35L	35	35	50	41	56	51.0	34.5	M 45 x 2			
	DLA - 42L	42	42	60	50	63	56.0	40.0	M 52 x 2			
S	DLA - 06S	6	6	17	12	31	27.0	16.0	M 14 x 1,5			
	DLA - 08S	8	8	19	14	32	27.5	17.0	M 16 x 1,5			
	DLA - 10S	10	10	22	17	34	30.0	17.5	M 18 x 1,5			
	DLA - 12S	12	12	24	17	38	31.0	21.5	M 20 x 1,5			
	DLA - 14S	14	14	27	19	40	35.0	22.0	M 22 x 1,5			
	DLA - 16S	16	16	30	24	43	36.5	24.5	M 24 x 1,5			
	DLA - 20S	20	20	36	27	48	44.5	26.5	M 30 x 2			
	DLA - 25S	25	25	46	36	54	50.0	30.0	M 36 x 2			
	DLA - 30S	30	30	50	41	62	55.0	35.5	M 42 x 2			
	DLA - 38S	38	38	60	50	72	63.0	41.0	M 52 x 2			

### Adjustable Branch Tee with Standpipe

#### DBTA

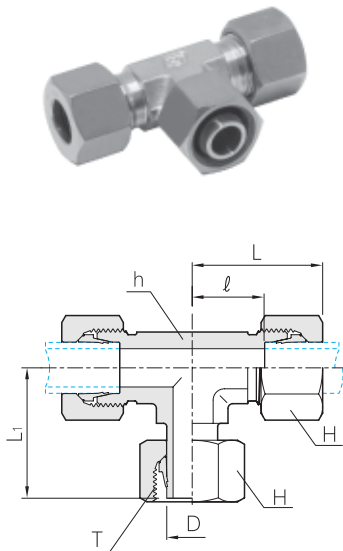

Series	Part No.	Tube O.D.	D	H <sub>1</sub>	h	L	L <sub>1</sub>	l	T			
L	DBTA - 06L	6	6	14	12	27	26.0	12.0	M 12 x 1,5			
	DBTA - 08L	8	8	17	12	29	27.5	14.0	M 14 x 1,5			
	DBTA - 10L	10	10	19	14	30	29.0	15.0	M 16 x 1,5			
	DBTA - 12L	12	12	22	17	32	29.5	17.0	M 18 x 1,5			
	DBTA - 15L	15	15	27	19	36	32.5	21.0	M 22 x 1,5			
	DBTA - 18L	18	18	32	24	40	35.5	23.5	M 26 x 1,5			
	DBTA - 22L	22	22	36	27	44	38.5	27.5	M 30 x 2			
	DBTA - 28L	28	28	41	36	47	41.5	30.5	M 36 x 2			
	DBTA - 35L	35	35	50	41	56	51.0	34.5	M 45 x 2			
	DBTA - 42L	42	42	60	50	63	56.0	40.0	M 52 x 2			
S	DBTA - 06S	6	6	17	12	31	27.0	16.0	M 14 x 1,5			
	DBTA - 08S	8	8	19	14	32	27.5	17.0	M 16 x 1,5			
	DBTA - 10S	10	10	22	17	34	30.0	17.5	M 18 x 1,5			
	DBTA - 12S	12	12	24	17	38	31.0	21.5	M 20 x 1,5			
	DBTA - 14S	14	14	27	19	40	35.0	22.0	M 22 x 1,5			
	DBTA - 16S	16	16	30	24	43	36.5	24.5	M 24 x 1,5			
	DBTA - 20S	20	20	36	27	48	44.5	26.5	M 30 x 2			
	DBTA - 25S	25	25	46	36	54	50.0	30.0	M 36 x 2			
	DBTA - 30S	30	30	50	41	62	55.0	35.5	M 42 x 2			
	DBTA - 38S	38	38	60	50	72	63.0	41.0	M 52 x 2			

Dimensions are given for approximate length with tightened nut. All dimensions are in millimeters for reference only, subject to change.  
Pre-set nut and cutting ring for connection are provided without male stud.  
Please refer to final assembly instructions on page 67.

## Adjustable Run Tee with Standpipe

### DRTA

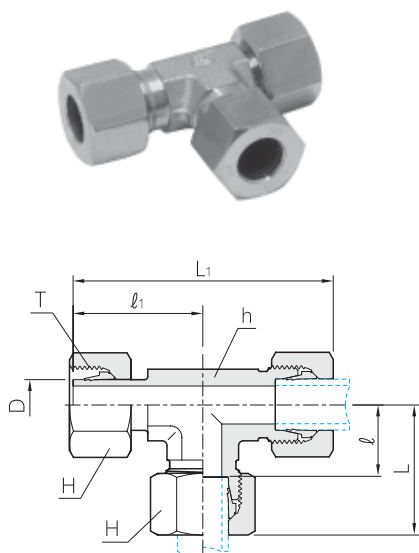

Series	Part No.	Tube O.D.	D	h	H	L	L <sub>1</sub>	ℓ	ℓ <sub>1</sub>	T		
L	DRTA - 06L	6	6	12	14	27	53	12.0	26.0	M 12 x 1.5		
	DRTA - 08L	8	8	12	17	29	56	14.0	27.5	M 14 x 1.5		
	DRTA - 10L	10	10	14	19	30	59	15.0	29.0	M 16 x 1.5		
	DRTA - 12L	12	12	17	22	32	62	17.0	29.5	M 18 x 1.5		
	DRTA - 15L	15	15	19	27	36	69	21.0	32.5	M 22 x 1.5		
	DRTA - 18L	18	18	24	32	40	75	23.5	35.5	M 26 x 1.5		
	DRTA - 22L	22	22	27	36	44	83	27.5	38.5	M 30 x 2		
	DRTA - 28L	28	28	36	41	47	91	30.5	41.5	M 36 x 2		
	DRTA - 35L	35	35	41	50	56	111	34.5	51.0	M 45 x 2		
	DRTA - 42L	42	42	50	60	63	123	40.0	56.0	M 52 x 2		
S	DRTA - 06S	6	6	12	17	31	58	16.0	27.0	M 14 x 1.5		
	DRTA - 08S	8	8	14	19	32	61	17.0	27.5	M 16 x 1.5		
	DRTA - 10S	10	10	17	22	34	66	17.5	30.0	M 18 x 1.5		
	DRTA - 12S	12	12	17	24	38	71	21.5	31.0	M 20 x 1.5		
	DRTA - 14S	14	14	19	27	40	75	22.0	35.0	M 22 x 1.5		
	DRTA - 16S	16	16	24	30	43	79	24.5	36.5	M 24 x 1.5		
	DRTA - 20S	20	20	27	36	48	93	26.5	44.5	M 30 x 2		
	DRTA - 25S	25	25	36	46	54	105	30.0	50.0	M 36 x 2		
	DRTA - 30S	30	30	41	50	62	119	35.5	55.0	M 42 x 2		
	DRTA - 38S	38	38	50	60	72	138	41.0	63.0	M 52 x 2		

## Swivel Adjustable Elbow with Cone

### DEW

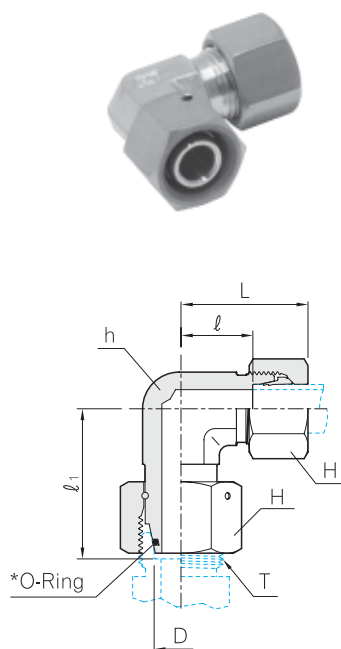

Series	Part No.	Tube O.D. D	H	h	L	ℓ	ℓ <sub>1</sub>	T		
L	DEW - 06L	6	14	12	27	12.0	26.0	M 12 x 1.5		
	DEW - 08L	8	17	12	29	14.0	27.5	M 14 x 1.5		
	DEW - 10L	10	19	14	30	15.0	29.0	M 16 x 1.5		
	DEW - 12L	12	22	17	32	17.0	29.5	M 18 x 1.5		
	DEW - 15L	15	27	19	36	21.0	32.5	M 22 x 1.5		
	DEW - 18L	18	32	24	40	23.5	35.5	M 26 x 1.5		
	DEW - 22L	22	36	27	44	27.5	38.5	M 30 x 2		
	DEW - 28L	28	41	36	47	30.5	41.5	M 36 x 2		
	DEW - 35L	35	50	41	56	34.5	51.0	M 45 x 2		
	DEW - 42L	42	60	50	63	40.0	56.0	M 52 x 2		
S	DEW - 06S	6	17	12	31	16.0	27.0	M 14 x 1.5		
	DEW - 08S	8	19	14	32	17.0	27.5	M 16 x 1.5		
	DEW - 10S	10	22	17	34	17.5	30.0	M 18 x 1.5		
	DEW - 12S	12	24	17	38	21.5	31.0	M 20 x 1.5		
	DEW - 14S	14	27	19	40	22.0	35.0	M 22 x 1.5		
	DEW - 16S	16	30	24	43	24.5	36.5	M 24 x 1.5		
	DEW - 20S	20	36	27	48	26.5	44.5	M 30 x 2		
	DEW - 25S	25	36	36	54	30.0	50.0	M 36 x 2		
	DEW - 30S	30	50	41	62	35.5	55.0	M 42 x 2		
	DEW - 38S	38	60	50	72	41.0	63.0	M 52 x 2		

Dimensions are given for approximate length with tightened nut. All dimensions are in millimeters for reference only, subject to change.

O-Ring for connection is provided without male stud.

Please refer to final assembly instructions on page 67.

\* The standard O-Ring material is NBR(e.g. Perbunan®) however FPM(e.g. Viton®) is also available on request (See Page 3).

Swivel Adjustable Branch Tee with Cone  
**DET**

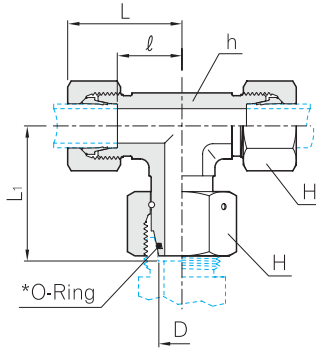

Series	Part No.	Tube O.D. D	H	h	L	L <sub>1</sub>	ℓ	T	PN(bar)	
									C.Steel	SS316
L	DET - 06L	6	14	12	27	26.0	12.0	M 12 x 1.5	500	315
	DET - 08L	8	17	12	29	27.5	14.0	M 14 x 1.5	500	315
	DET - 10L	10	19	14	30	29.0	15.0	M 16 x 1.5	500	315
	DET - 12L	12	22	17	32	29.5	17.0	M 18 x 1.5	400	315
	DET - 15L	15	27	19	36	32.5	21.0	M 22 x 1.5	400	315
	DET - 18L	18	32	24	40	35.5	23.5	M 26 x 1.5	400	315
	DET - 22L	22	36	27	44	38.5	27.5	M 30 x 2	250	160
	DET - 28L	28	41	36	47	41.5	30.5	M 36 x 2	250	160
	DET - 35L	35	50	41	56	51.0	34.5	M 45 x 2	250	160
DET - 42L	42	60	50	63	56.0	40.0	M 52 x 2	250	160	
S	DET - 06S	6	17	12	31	27.0	16.0	M 14 x 1.5	800	630
	DET - 08S	8	19	14	32	27.5	17.0	M 16 x 1.5	800	630
	DET - 10S	10	22	17	34	30.0	17.5	M 18 x 1.5	800	630
	DET - 12S	12	24	17	38	31.0	21.5	M 20 x 1.5	630	630
	DET - 14S	14	27	19	40	35.0	22.0	M 22 x 1.5	630	630
	DET - 16S	16	30	24	43	36.5	24.5	M 24 x 1.5	630	400
	DET - 20S	20	36	27	48	44.5	26.5	M 30 x 2	420	400
	DET - 25S	25	46	36	54	50.0	30.0	M 36 x 2	420	400
	DET - 30S	30	50	41	62	55.0	35.5	M 42 x 2	420	400
DET - 38S	38	60	50	72	63.0	41.0	M 52 x 2	420	315	

Swivel Adjustable Run Tee with Cone  
**DEL**

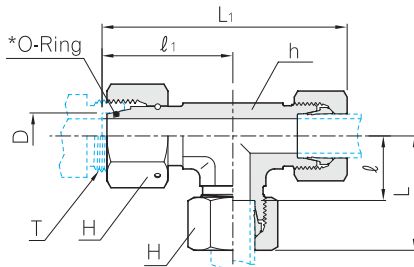

Series	Part No.	Tube O.D. D	H	h	L	L <sub>1</sub>	ℓ	ℓ <sub>1</sub>	T	PN(bar)	
										C.Steel	SS316
L	DEL - 06L	6	14	12	27	53	12.0	26.0	M 12 x 1.5	500	315
	DEL - 08L	8	17	12	29	56	14.0	27.5	M 14 x 1.5	500	315
	DEL - 10L	10	19	14	30	59	15.0	29.0	M 16 x 1.5	500	315
	DEL - 12L	12	22	17	32	61	17.0	29.5	M 18 x 1.5	400	315
	DEL - 15L	15	27	19	36	69	21.0	32.5	M 22 x 1.5	400	315
	DEL - 18L	18	32	24	40	75	23.5	35.5	M 26 x 1.5	400	315
	DEL - 22L	22	36	27	44	82	27.5	38.5	M 30 x 2	250	160
	DEL - 28L	28	41	36	47	89	30.5	41.5	M 36 x 2	250	160
	DEL - 35L	35	50	41	56	107	34.5	51.0	M 45 x 2	250	160
DEL - 42L	42	60	50	63	119	40.0	56.0	M 52 x 2	250	160	
S	DEL - 06S	6	17	12	31	58	16.0	27.0	M 14 x 1.5	800	630
	DEL - 08S	8	19	14	32	59	17.0	27.5	M 16 x 1.5	800	630
	DEL - 10S	10	22	17	34	64	17.5	30.0	M 18 x 1.5	800	630
	DEL - 12S	12	24	17	38	69	21.5	31.0	M 20 x 1.5	630	630
	DEL - 14S	14	27	19	40	75	22.0	35.0	M 22 x 1.5	630	630
	DEL - 16S	16	30	24	43	79	24.5	36.5	M 24 x 1.5	630	400
	DEL - 20S	20	36	27	48	93	26.5	44.5	M 30 x 2	420	400
	DEL - 25S	25	46	36	54	104	30.0	50.0	M 36 x 2	420	400
	DEL - 30S	30	50	41	62	117	35.5	55.0	M 42 x 2	420	400
DEL - 38S	38	60	50	72	135	41.0	63.0	M 52 x 2	420	315	

Dimensions are given for approximate length with tightened nut. All dimensions are in millimeters for reference only, subject to change. Pre-set nut and cutting ring for connection are provided without male stud. Please refer to final assembly instructions on page 67.



## Tube To Tube Port (Adjustable Fittings)

### Standpipe Reducer DKOR

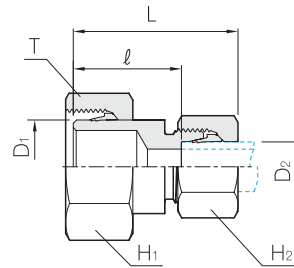

#### Series L (Light)

Part No.	Tube O.D.		H <sub>1</sub>	H <sub>2</sub>	L	ℓ	T		
	D <sub>1</sub>	D <sub>2</sub>							
DKOR 08L-06L	8	6	17	14	38	23.5	M 14 x 1.5		
DKOR 10L-06L	10	6	19	14	38	23.5	M 16 x 1.5		
DKOR 10L-08L		8		17					
DKOR 12L-06L	12	6	22	14	38	23.5	M 18 x 1.5		
DKOR 12L-08L		8		17	38	23.5			
DKOR 12L-10L		10		19	39	24.5			
DKOR 15L-06L	15	6	27	14	38	23.5	M 22 x 1.5		
DKOR 15L-08L		8		17	38	23.5			
DKOR 15L-10L		10		19	39	24.5			
DKOR 15L-12L		12		22	39	24.5			
DKOR 18L-06L	18	6	32	14	39	24.5	M 26 x 1.5		
DKOR 18L-08L		8		17	39	24.5			
DKOR 18L-10L		10		19	40	25.5			
DKOR 18L-12L		12		22	40	25.5			
DKOR 18L-15L		15		27	42	26.5			
DKOR 22L-06L	22	6	36	14	40	25.5	M 30 x 2		
DKOR 22L-08L		8		17	40	25.5			
DKOR 22L-10L		10		19	41	26.5			
DKOR 22L-12L		12		22	41	26.5			
DKOR 22L-15L		15		27	43	27.5			
DKOR 22L-18L		18		32	43	27.0			
DKOR 28L-06L	28	6	41	14	41	26.5	M 36 x 2		
DKOR 28L-08L		8		17	41	26.5			
DKOR 28L-10L		10		19	42	27.5			
DKOR 28L-12L		12		22	42	27.5			
DKOR 28L-15L		15		27	44	28.5			
DKOR 28L-18L		18		32	44	28.0			
DKOR 28L-22L		22		36	46	30.0			
DKOR 35L-06L	35	6	50	14	46	31.5	M 45 x 2		
DKOR 35L-08L		8		17	46	31.5			
DKOR 35L-10L		10		19	47	32.5			
DKOR 35L-12L		12		22	47	32.5			
DKOR 35L-15L		15		27	49	33.5			
DKOR 35L-18L		18		32	49	33.0			
DKOR 35L-22L		22		36	51	35.0			
DKOR 35L-28L		28		41	52	35.0			
DKOR 42L-10L	42	10	60	19	48	33.5	M 52 x 2		
DKOR 42L-12L		12		22	48	33.5			
DKOR 42L-15L		15		27	50	34.5			
DKOR 42L-18L		18		32	50	34.0			
DKOR 42L-22L		22		36	52	36.0			
DKOR 42L-28L		28		41	53	36.0			
DKOR 42L-35L		35		50	57	35.0			

#### Series S (Heavy)

Part No.	Tube O.D.		H <sub>1</sub>	H <sub>2</sub>	L	ℓ	T		
	D <sub>1</sub>	D <sub>2</sub>							
DKOR 08S-06S	8	6	17	17	40	25.0	M 16 x 1.5		
DKOR 10S-06S	10	6	19	17	41	26.0	M 18 x 1.5		
DKOR 10S-08S		8		19	41	26.0			
DKOR 12S-06S	12	6	22	17	42	27.0	M 20 x 1.5		
DKOR 12S-08S		8		19	42	27.0			
DKOR 12S-10S		10		22	43	26.5			
DKOR 14S-06S	14	6	27	17	44	29.0	M 22 x 1.5		
DKOR 14S-08S		8		19	44	29.0			
DKOR 14S-10S		10		22	45	28.5			
DKOR 14S-12S		12		24	45	28.5			
DKOR 16S-06S	16	6	32	17	44	29.0	M 24 x 1.5		
DKOR 16S-08S		8		19	44	29.0			
DKOR 16S-10S		10		22	45	28.5			
DKOR 16S-12S		12		24	45	28.5			
DKOR 16S-14S		14		27	48	30.0			
DKOR 20S-06S	20	6	36	17	49	34.0	M 30 x 2		
DKOR 20S-08S		8		19	49	34.0			
DKOR 20S-10S		10		22	50	33.5			
DKOR 20S-12S		12		24	50	33.5			
DKOR 20S-14S		14		27	53	35.0			
DKOR 20S-16S		16		30	53	34.5			
DKOR 25S-06S	25	6	41	17	52	37.0	M 36 x 2		
DKOR 25S-08S		8		19	52	37.0			
DKOR 25S-10S		10		22	53	36.5			
DKOR 25S-12S		12		24	53	36.5			
DKOR 25S-14S		14		27	55	37.0			
DKOR 25S-16S		16		30	55	36.5			
DKOR 25S-20S		20		36	59	37.5			
DKOR 30S-06S	30	6	50	17	54	39.0	M 42 x 2		
DKOR 30S-08S		8		19	54	39.0			
DKOR 30S-10S		10		22	55	38.5			
DKOR 30S-12S		12		24	55	38.5			
DKOR 30S-14S		14		27	58	40.0			
DKOR 30S-16S		16		30	58	39.5			
DKOR 30S-20S		20		36	61	39.5			
DKOR 30S-25S		25		46	64	40.0			
DKOR 38S-06S	38	6	60	17	58	43.0	M 52 x 2		
DKOR 38S-08S		8		19	58	43.0			
DKOR 38S-10S		10		22	59	42.5			
DKOR 38S-12S		12		24	59	42.5			
DKOR 38S-14S		14		27	62	44.0			
DKOR 38S-16S		16		30	62	43.5			
DKOR 38S-20S		20		36	65	43.5			
DKOR 38S-25S		25		46	68	44.0			
DKOR 38S-30S		30		50	71	44.5			

Dimensions are given for approximate length with tightened nut. All dimensions are in millimeters for reference only, subject to change. Pre-set nut and cutting ring for connection are provided without male stud. Please refer to final assembly instructions on page 67.

## 24° Tube Fittings-DIN 2353 & ISO 8434-1

### Reducer DR

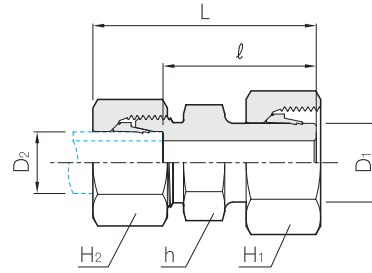

#### Series L (Light)

Part No.	Tube O.D.		H <sub>1</sub>	H <sub>2</sub>	h	L	ℓ	PN(bar) S316
	D <sub>1</sub>	D <sub>2</sub>						
DR08L - 06L	8	6	17	14	12	40	25.5	315
DR10L - 06L	10	6	19	14	12	42	27.5	315
DR10L - 08L		8	19	17	14	43	27.5	315
DR12L - 06L	12	6	22	14	14	42	27.5	315
DR12L - 08L		8	22	17	14	43	27.5	315
DR12L - 10L		10	22	19	17	44	28.5	315
DR15L - 06L	15	6	27	14	19	44	29.0	315
DR15L - 08L		8	27	17	19	44	29.0	315
DR15L - 10L		10	27	19	19	45	30.0	315
DR15L - 12L		12	27	22	19	45	30.0	315
DR18L - 06L	18	6	32	14	19	46	31.0	315
DR18L - 08L		8	32	17	19	46	31.0	315
DR18L - 10L		10	32	19	19	47	32.0	315
DR18L - 12L		12	32	22	19	47	32.0	315
DR18L - 15L		15	32	27	22	49	33.0	315
DR22L - 06L	22	6	36	14	24	48	33.0	160
DR22L - 08L		8	36	17	24	48	33.0	160
DR22L - 10L		10	36	19	24	49	34.0	160
DR22L - 12L		12	36	22	24	49	34.0	160
DR22L - 15L		15	36	27	24	50	35.0	160
DR22L - 18L		18	36	32	27	51	34.5	160
DR28L - 06L	28	6	41	14	30	48	33.0	160
DR28L - 08L		8	41	17	30	48	33.0	160
DR28L - 10L		10	41	19	30	49	34.0	160
DR28L - 12L		12	41	22	30	49	34.0	160
DR28L - 15L		15	41	27	30	50	35.0	160
DR28L - 18L		18	41	32	30	51	36.0	160
DR28L - 22L		22	41	36	32	53	36.5	160
DR35L - 06L	35	6	50	14	36	53	38.5	160
DR35L - 08L		8	50	17	36	53	38.5	160
DR35L - 10L		10	50	19	36	55	39.5	160
DR35L - 12L		12	50	22	36	55	39.5	160
DR35L - 15L		15	50	27	36	56	40.5	160
DR35L - 18L		18	50	32	36	56	40.0	160
DR35L - 22L		22	50	36	36	58	42.0	160
DR35L - 28L		28	50	41	36	59	42.0	160
DR42L - 06L	42	6	60	14	46	56	41.0	160
DR42L - 08L		8	60	17	46	56	41.0	160
DR42L - 10L		10	60	19	46	58	42.0	160
DR42L - 12L		12	60	22	46	58	42.0	160
DR42L - 15L		15	60	27	46	60	43.0	160
DR42L - 18L		18	60	32	46	60	42.5	160
DR42L - 22L		22	60	36	46	62	44.5	160
DR42L - 28L			60	41	46	64	44.5	160
DR42L - 35L		35	60	50	46	67	43.5	160

#### Series S (Heavy)

Part No.	Tube O.D.		H <sub>1</sub>	H <sub>2</sub>	h	L	ℓ	PN(bar) S316
	D <sub>1</sub>	D <sub>2</sub>						
DR08S - 06S	8	6	19	17	14	43	28.0	630
DR10S - 06S	10	6	22	17	14	45	30.5	630
DR10S - 08S		8	22	19	17	45	30.5	630
DR12S - 06S	12	6	24	17	14	47	32.5	630
DR12S - 08S		8	24	19	17	47	32.5	630
DR12S - 10S		10	24	22	19	48	32.0	630
DR14S - 06S	14	6	27	17	17	51	36.5	630
DR14S - 08S		8	27	19	17	51	36.5	630
DR14S - 10S		10	27	22	19	52	36.0	630
DR14S - 12S		12	27	24	22	52	36.0	630
DR16S - 06S	16	6	30	17	17	53	38.5	400
DR16S - 08S		8	30	19	17	53	38.5	400
DR16S - 10S		10	30	22	19	54	38.0	400
DR16S - 12S		12	30	24	22	55	38.5	400
DR16S - 14S		14	30	27	22	57	39.5	400
DR20S - 06S	20	6	36	17	22	58	43.0	400
DR20S - 08S		8	36	19	22	58	43.0	400
DR20S - 10S		10	36	22	22	59	42.5	400
DR20S - 12S		12	36	24	22	59	42.5	400
DR20S - 14S		14	36	27	22	62	44.0	400
DR20S - 16S		16	36	30	24	62	43.5	400
DR25S - 06S	25	6	46	17	27	62	47.5	400
DR25S - 08S		8	46	19	27	62	47.5	400
DR25S - 10S		10	46	22	27	63	47.0	400
DR25S - 12S		12	46	24	27	63	47.0	400
DR25S - 14S		14	46	27	27	66	48.5	400
DR25S - 16S		16	46	30	27	66	48.0	400
DR25S - 20S		20	46	36	30	70	48.0	400
DR30S - 06S	30	6	50	17	32	67	52.0	400
DR30S - 08S		8	50	19	32	67	52.0	400
DR30S - 10S		10	50	22	32	68	51.5	400
DR30S - 12S		12	50	24	32	68	51.5	400
DR30S - 14S		14	50	27	32	71	53.0	400
DR30S - 16S		16	50	30	32	71	52.5	400
DR30S - 20S		20	50	36	32	74	52.5	400
DR30S - 25S		25	50	46	36	77	53.0	400
DR38S - 06S	38	6	60	17	41	72	57.0	315
DR38S - 08S		8	60	19	41	72	57.0	315
DR38S - 10S		10	60	22	41	73	56.5	315
DR38S - 12S		12	60	24	41	73	56.5	315
DR38S - 14S		14	60	27	41	76	58.0	315
DR38S - 16S		16	60	30	41	76	57.5	315
DR38S - 20S		20	60	36	41	79	57.5	315
DR38S - 25S		25	60	46	41	82	58.0	315
DR38S - 30S		30	60	50	46	89	58.5	315

Dimensions are given for approximate length with tightened nut. All dimensions are in millimeters for reference only, subject to change.

## Swivel Reducing Adapter with Cone DRED

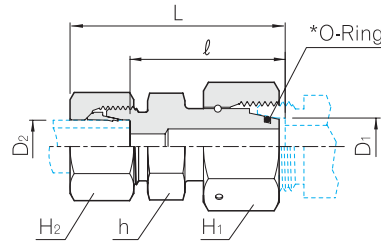
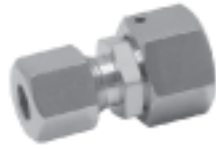

### Series L (Light)

Part No.	Tube O.D.		H <sub>1</sub>	H <sub>2</sub>	h	L	ℓ	PN(bar)	
	D <sub>1</sub>	D <sub>2</sub>						C.Steel	S316
DRED 08L-06L	8	6	17	14	12.0	38.0	23.5	500	315
DRED 10L-06L	10	6	19	14	14.0	40.0	25.0	500	315
DRED 10L-08L		8		17		40.0	25.0	500	315
DRED 12L-06L	12	6	22	14	17.0	40.0	25.0	400	315
DRED 12L-08L		8		17		40.0	25.0	400	315
DRED 12L-10L		10		19		41.0	26.0	400	315
DRED 15L-06L	15	6	27	14	19.0	43.0	28.5	400	315
DRED 15L-08L		8		17		43.0	28.5	400	315
DRED 15L-10L		10		19		44.0	29.5	400	315
DRED 15L-12L		12		22		44.0	29.5	400	315
DRED 18L-06L	18	6	32	14	24.0	43.0	28.0	400	315
DRED 18L-08L		8		17		43.0	28.0	400	315
DRED 18L-10L		10		19		44.0	29.0	400	315
DRED 18L-12L		12		22		44.0	29.0	400	315
DRED 18L-15L		15		27		45.0	30.0	400	315
DRED 22L-06L	22	6	36	14	27.0	47.0	32.0	250	160
DRED 22L-08L		8		17		47.0	32.0	250	160
DRED 22L-10L		10		19		48.0	33.0	250	160
DRED 22L-12L		12		22		48.0	33.0	250	160
DRED 22L-15L		15		27		49.0	34.0	250	160
DRED 22L-18L		18		32		50.0	33.5	250	160
DRED 28L-06L	28	6	41	14	32.0	49.0	34.0	250	160
DRED 28L-08L		8		17		49.0	34.0	250	160
DRED 28L-10L		10		19		50.0	35.0	250	160
DRED 28L-12L		12		22		50.0	35.0	250	160
DRED 28L-15L		15		27		51.0	36.0	250	160
DRED 28L-18L		18		32		52.0	35.5	250	160
DRED 28L-22L		22		36		54.0	37.5	250	160
DRED 35L-06L	35	6	50	14	41.0	52.0	37.0	250	160
DRED 35L-08L		8		17		52.0	37.0	250	160
DRED 35L-10L		10		19		53.0	38.0	250	160
DRED 35L-12L		12		22		53.0	38.0	250	160
DRED 35L-15L		15		27		54.0	39.0	250	160
DRED 35L-18L		18		32		55.0	38.5	250	160
DRED 35L-22L		22		36		57.0	40.5	250	160
DRED 35L-28L		28		41		57.0	40.5	250	160
DRED 42L-06L	42	6	60	14	50.0	55.0	40.5	250	160
DRED 42L-08L		8		17		55.0	40.5	250	160
DRED 42L-10L		10		19		56.0	41.5	250	160
DRED 42L-12L		12		22		56.0	41.5	250	160
DRED 42L-15L		15		27		58.0	42.5	250	160
DRED 42L-18L		18		32		58.0	42.0	250	160
DRED 42L-22L		22		36		60.0	44.0	250	160
DRED 42L-28L		28		41		61.0	44.0	250	160
DRED 42L-35L		35		50		65.0	43.0	250	160

### Series S (Heavy)

Part No.	Tube O.D.		H <sub>1</sub>	H <sub>2</sub>	h	L	ℓ	PN(bar)	
	D <sub>1</sub>	D <sub>2</sub>						C.Steel	S316
DRED 08S-06S	8	6	19	17	14.0	42.0	27.0	800	630
DRED 10S-06S	10	6	22	17	17.0	42.0	27.5	800	630
DRED 10S-08S		8		19		42.0	27.5	800	630
DRED 12S-06S	12	6	24	17	17.0	44.0	29.0	630	630
DRED 12S-08S		8		19		44.0	29.0	630	630
DRED 12S-10S		10		22		46.0	29.5	630	630
DRED 14S-06S	14	6	27	17	19.0	46.0	31.5	630	630
DRED 14S-08S		8		19		46.0	31.5	630	630
DRED 14S-10S		10		22		47.0	31.0	630	630
DRED 14S-12S		12		24		47.0	31.0	630	630
DRED 16S-06S	16	6	30	17	22.0	47.0	32.0	630	400
DRED 16S-08S		8		19		47.0	32.0	630	400
DRED 16S-10S		10		22		48.0	31.5	630	400
DRED 16S-12S		12		24		48.0	31.5	630	400
DRED 16S-14S		14		27		51.0	33.0	630	400
DRED 20S-06S	20	6	36	17	24.0	51.0	36.0	420	400
DRED 20S-08S		8		19		51.0	36.0	420	400
DRED 20S-10S		10		22		52.0	35.5	420	400
DRED 20S-12S		12		24		52.0	35.5	420	400
DRED 20S-14S		14		27		55.0	37.0	420	400
DRED 20S-16S		16		30		55.0	36.5	420	400
DRED 25S-06S	25	6	46	17	36.0	53.0	38.5	420	400
DRED 25S-08S		8		19		53.0	38.5	420	400
DRED 25S-10S		10		22		54.0	38.0	420	400
DRED 25S-12S		12		24		54.0	38.0	420	400
DRED 25S-14S		14		27		57.0	39.5	420	400
DRED 25S-16S		16		30		57.0	39.0	420	400
DRED 25S-20S		20		36		61.0	39.0	420	400
DRED 30S-06S	30	6	50	17	32.0	59.0	44.0	420	400
DRED 30S-08S		8		19		59.0	44.0	420	400
DRED 30S-10S		10		22		60.0	43.5	420	400
DRED 30S-12S		12		24		60.0	43.5	420	400
DRED 30S-14S		14		27		63.0	45.0	420	400
DRED 30S-16S		16		30		63.0	44.5	420	400
DRED 30S-20S		20		36		66.0	44.5	420	400
DRED 30S-25S		25		46		69.0	45.0	420	400
DRED 38S-06S	38	6	60	17	50.0	62.0	47.5	420	315
DRED 38S-08S		8		19		62.0	47.5	420	315
DRED 38S-10S		10		22		63.0	47.0	420	315
DRED 38S-12S		12		24		63.0	47.0	420	315
DRED 38S-14S		14		27		66.0	48.5	420	315
DRED 38S-16S		16		30		66.0	48.0	420	315
DRED 38S-20S		20		36		70.0	48.0	420	315
DRED 38S-25S		25		46		73.0	48.5	420	315
DRED 38S-30S		30		50		76.0	49.0	420	315

Dimensions are given for approximate length with tightened nut. All dimensions are in millimeters for reference only, subject to change.

O-Ring for connection is provided without male stud.

Please refer to final assembly instructions on page 67.

\* The standard O-Ring material is NBR(e.g. Perbunan®) however FPM(e.g. Viton®) is also available on request (See Page 3).

## 24° Tube Fittings-DIN 2353 & ISO 8434-1

### Adapter (ISO/BSP Parallel / Metric Parallel) with \*ED-Ring DA-GED/MED

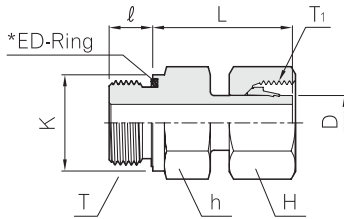
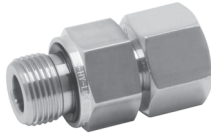

Form E stud end

#### for ISO/BSP Paralled

Series	Part No.	Tube O.D. D	H	h	K	L	ℓ	T	T <sub>1</sub>	PN(bar)		
										C.Steel	SS316	BRASS
L	DA 06L-01GED	6	14	14	14	24,5	8	G 1/8	M 12 x 1,5	315	315	200
	DA 08L-02GED	8	17	19	19	29,5	12	G 1/4	M 14 x 1,5	315	315	200
	DA 10L-02GED	10	19	19	19	27,5	12	G 1/4	M 16 x 1,5	315	315	200
	DA 12L-03GED	12	22	22	22	34,0	12	G 3/8	M 18 x 1,5	315	315	200
	DA 15L-04GED	15	27	27	27	32,0	14	G 1/2	M 22 x 1,5	315	315	200
	DA 18L-04GED	18	32	27	27	31,5	14	G 1/2	M 26 x 1,5	315	315	200
	DA 22L-06GED	22	36	32	32	32,5	16	G 3/4	M 30 x 2	160	160	100
	DA 28L-08GED	28	41	41	40	35,0	18	G 1	M 36 x 2	160	160	
	DA 35L-10GED	35	50	50	50	42,5	20	G 1 1/4	M 45 x 2	160	160	
	DA 42L-12GED	42	60	55	55	46,5	22	G 1 1/2	M 52 x 2	160	160	
S	DA 06S-02GED	6	17	19	19	27,0	12	G 1/4	M 14 x 1,5	630	630	
	DA 08S-02GED	8	19	19	19	29,5	12	G 1/4	M 16 x 1,5	630	630	
	DA 10S-03GED	10	22	22	22	32,0	12	G 3/8	M 18 x 1,5	630	630	
	DA 12S-03GED	12	24	22	22	34,0	12	G 3/8	M 20 x 1,5	630	630	
	DA 12S-04GED	12	24	27	27	34,5	14	G 1/2	M 20 x 1,5	630	630	
	DA 14S-04GED	14	27	27	27	36,5	14	G 1/2	M 22 x 1,5	630		630
	DA 16S-04GED	16	30	27	27	37,0	14	G 1/2	M 24 x 1,5	400	400	
	DA 16S-06GED	16	30	32	32	39,0	16	G 3/4	M 24 x 1,5	400		
	DA 20S-06GED	20	36	32	32	43,0	16	G 3/4	M 30 x 2	400	400	
	DA 25S-08GED	25	46	41	40	48,0	18	G 1	M 36 x 2	400	400	
DA 30S-10GED	30	50	50	50	51,0	20	G 1 1/4	M 42 x 2	400	400		
DA 38S-12GED	38	60	55	55	60,0	22	G 1 1/2	M 52 x 2	315	315		

#### for Metric Parallel

Series	Part No.	Tube O.D. D	H	h	K	L	ℓ	T	T <sub>1</sub>	PN(bar)	
										C.Steel	SS316
L	DA 06L-M10ED	6	14	14	14	24,5	8	M 10 x 1,0	M 12 x 1,5	315	315
	DA 08L-M12ED	8	17	17	17	26,5	12	M 12 x 1,5	M 14 x 1,5	315	315
	DA 10L-M14ED	10	19	19	19	27,5	12	M 14 x 1,5	M 16 x 1,5	315	315
	DA 12L-M16ED	12	22	22	22	30,5	12	M 16 x 1,5	M 18 x 1,5	315	315
	DA 15L-M18ED	15	27	24	24	31,5	14	M 18 x 1,5	M 22 x 1,5	315	315
	DA 18L-M22ED	18	32	27	27	31,5	14	M 22 x 1,5	M 26 x 1,5	315	315
	DA 22L-M26ED	22	36	32	32	32,5	16	M 26 x 1,5	M 30 x 2,0	160	160
	DA 28L-M33ED	28	41	41	40	35,0	18	M 33 x 2,0	M 36 x 2,0	160	160
	DA 35L-M42ED	35	50	50	50	42,5	20	M 42 x 2,0	M 45 x 2,0	160	160
	DA 42L-M48ED	42	60	55	55	46,5	22	M 48 x 2,0	M 52 x 2,0	160	160
S	DA 06S-M10ED	6	17	17	17	27,0	12	M 12 x 1,5	M 14 x 1,5	630	630
	DA 08S-M14ED	8	19	19	19	29,5	12	M 14 x 1,5	M 16 x 1,5	630	630
	DA 10S-M16ED	10	22	22	22	32,0	12	M 16 x 1,5	M 18 x 1,5	630	630
	DA 12S-M18ED	12	24	24	24	34,0	12	M 18 x 1,5	M 20 x 1,5	630	630
	DA 14S-M20ED	14	27	27	27	36,5	14	M 20 x 1,5	M 22 x 1,5	630	630
	DA 16S-M22ED	16	30	27	27	37,0	14	M 22 x 1,5	M 24 x 1,5	400	400
	DA 20S-M27ED	20	36	32	32	43,0	16	M 27 x 2,0	M 30 x 2,0	400	400
	DA 25S-M33ED	25	46	41	40	48,0	18	M 33 x 2,0	M 36 x 2,0	400	400
	DA 30S-M42ED	30	50	50	50	51,0	20	M 42 x 2,0	M 42 x 2,0	400	400
	DA 38S-M48ED	38	60	55	55	60,0	22	M 48 x 2,0	M 52 x 2,0	315	315

Dimensions are given for approximate length with tightened nut. All dimensions are in millimeters for reference only, subject to change.

O-Ring for connection is provided without male stud.

Please refer to final assembly instructions on page 67.

\* The standard ED-Ring material is NBR(e.g. perbunan®) however FPM(e.g. Viton®) is also available on Request (See Page3).

# Swivel Adapter (ISO/BSP Parallel / Metric Parallel) with Cone and \*ED-Ring DEGE-G/M

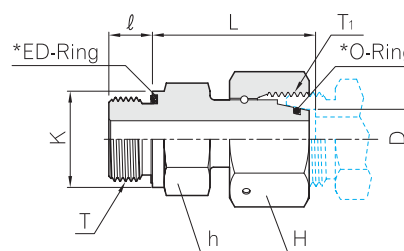
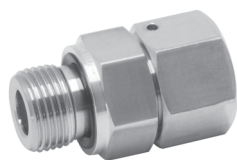

Form E stud end

### for ISO/BSP Parallel

Series	Part No.	Tube O.D. D	H	h	K	L	ℓ	T	T <sub>1</sub>	PN(bar)	
										C.Steel	SS316
L	DEGE 06L - 01G	6	14	14	14	24,5	8	G 1/8	M 12 x 1,5	500	315
	DEGE 08L - 02G	8	17	19	19	29,5	12	G 1/4	M 14 x 1,5	500	315
	DEGE 10L - 02G	10	19	19	19	27,5	12	G 1/4	M 16 x 1,5	500	315
	DEGE 12L - 03G	12	22	22	22	34,0	12	G 3/8	M 18 x 1,5	400	315
	DEGE 15L - 04G	15	27	27	27	32,0	14	G 1/2	M 22 x 1,5	400	315
	DEGE 18L - 04G	18	32	27	27	31,5	14	G 1/2	M 26 x 1,5	400	315
	DEGE 22L - 06G	22	36	32	32	32,5	16	G 3/4	M 30 x 2,0	250	160
	DEGE 28L - 08G	28	41	41	40	35,0	18	G 1	M 36 x 2,0	250	160
	DEGE 35L - 10G	35	50	50	50	42,5	20	G 1 1/4	M 45 x 2,0	250	160
DEGE 42L - 12G	42	60	55	55	46,5	22	G 1 1/2	M 52 x 2,0	250	160	
S	DEGE 06S - 02G	6	17	19	19	27,0	12	G 1/4	M 14 x 1,5	800	630
	DEGE 08S - 02G	8	19	19	19	29,5	12	G 1/4	M 16 x 1,5	800	630
	DEGE 10S - 03G	10	22	22	22	32,0	12	G 3/8	M 18 x 1,5	800	630
	DEGE 12S - 03G	12	24	22	22	34,0	12	G 3/8	M 20 x 1,5	630	630
	DEGE 14S - 04G	14	27	27	27	36,5	14	G 1/2	M 22 x 1,5	630	630
	DEGE 16S - 04G	16	30	27	27	37,0	14	G 1/2	M 24 x 1,5	630	400
	DEGE 20S - 06G	20	36	32	32	43,0	16	G 3/4	M 30 x 2,0	420	400
	DEGE 25S - 08G	25	46	41	40	48,0	18	G 1	M 36 x 2,0	420	400
	DEGE 30S - 10G	30	50	50	50	51,0	20	G 1 1/4	M 42 x 2,0	420	400
DEGE 38S - 12G	38	60	55	55	60,0	22	G 1 1/2	M 52 x 2,0	420	315	

### for Metric Paralled

Series	Part No.	Tube O.D. D	H	h	K	L	ℓ	T	T <sub>1</sub>	PN(bar)	
										C.Steel	SS316
L	DEGE 06L - M10	6	14	14	14	24,5	8	M 10 x 1,0	M 12 x 1,5	500	315
	DEGE 08L - M12	8	17	17	17	26,5	12	M 12 x 1,5	M 14 x 1,5	500	315
	DEGE 10L - M14	10	19	19	19	27,5	12	M 14 x 1,5	M 16 x 1,5	500	315
	DEGE 12L - M16	12	22	22	22	30,5	12	M 16 x 1,5	M 18 x 1,5	400	315
	DEGE 15L - M18	15	27	24	24	31,5	12	M 18 x 1,5	M 22 x 1,5	400	315
	DEGE 18L - M22	18	32	27	27	31,5	14	M 22 x 1,5	M 26 x 1,5	400	315
	DEGE 22L - M26	22	36	32	32	32,5	16	M 26 x 1,5	M 30 x 2,0	250	160
	DEGE 28L - M33	28	41	41	40	35,0	18	M 33 x 2,0	M 36 x 2,0	250	160
	DEGE 35L - M42	35	50	50	50	42,5	20	M 42 x 2,0	M 45 x 2,0	250	160
DEGE 42L - M48	42	60	55	55	46,5	22	M 48 x 2,0	M 52 x 2,0	250	160	
S	DEGE 06S - M12	6	17	17	17	27,0	12	M 12 x 1,5	M 14 x 1,5	800	630
	DEGE 08S - M14	8	19	19	19	29,5	12	M 14 x 1,5	M 16 x 1,5	800	630
	DEGE 10S - M16	10	22	22	22	32,0	12	M 16 x 1,5	M 18 x 1,5	800	630
	DEGE 12S - M18	12	24	24	24	34,0	12	M 18 x 1,5	M 20 x 1,5	630	630
	DEGE 14S - M20	14	27	27	26	36,5	14	M 20 x 1,5	M 22 x 1,5	630	630
	DEGE 16S - M22	16	30	27	27	37,0	14	M 22 x 1,5	M 24 x 1,5	630	400
	DEGE 20S - M27	20	36	32	32	43,0	16	M 27 x 2,0	M 30 x 2,0	420	400
	DEGE 25S - M33	25	46	41	40	48,0	18	M 33 x 2,0	M 36 x 2,0	420	400
	DEGE 30S - M42	30	50	50	50	51,0	20	M 42 x 2,0	M 42 x 2,0	420	400
DEGE 38S - M48	38	60	55	55	60,0	22	M 48 x 2,0	M 52 x 2,0	420	315	

Dimensions are given for approximate length with tightened nut. All dimensions are in millimeters for reference only, subject to change.

O-Ring for connection is provided without male stud.

Please refer to final assembly instructions on page 67.

\* The standard ED-Ring material is NBR(e.g. perbunan®) however FPM(e.g. Viton®) is also available on Request (See Page3).

Swivel Union With Cone  
**DUE**

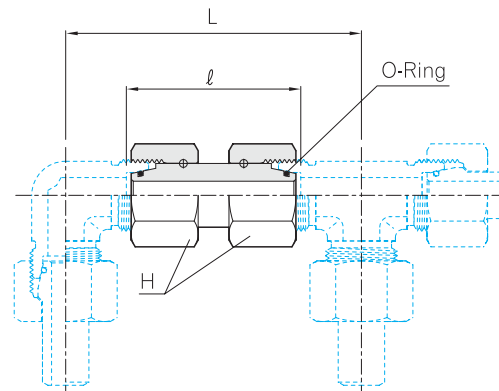

Series	Part No.	Tube O.D.	H	L	l	PN(bar)	
						C.Steel	SS316
L	DUE - 06L	6	17	61.0	33.0	500	315
	DUE - 08L	8	17	61.0	33.0	500	315
	DUE - 10L	10	19	64.0	34.0	500	315
	DUE - 12L	12	22	68.0	34.0	400	315
	DUE - 15L	15	27	81.0	39.0	400	315
	DUE - 18L	18	32	85.0	38.0	400	315
	DUE - 22L	22	36	99.0	44.0	250	160
	DUE - 28L	28	46	109.0	48.0	250	160
	DUE - 35L	35	50	121.0	52.0	250	160
DUE - 42L	42	60	137.0	57.0	250	160	
S	DUE - 06S	6	17	65.0	33.0	800	630
	DUE - 08S	8	19	68.0	34.0	800	630
	DUE - 10S	10	22	70.0	35.0	800	630
	DUE - 12S	12	24	81.0	38.0	630	630
	DUE - 14S	14	27	85.0	41.0	630	630
	DUE - 16S	16	30	91.0	42.0	630	400
	DUE - 20S	20	36	101.0	48.0	420	400
	DUE - 25S	25	46	113.0	53.0	420	400
	DUE - 30S	30	50	133.0	62.0	420	400
DUE - 38S	38	60	139.0	67.0	420	315	

Dimensions are given for approximate length with tightened nut. All dimensions are in millimeters for reference only, subject to change.

O-Ring for connection is provided without male stud.

Please refer to final assembly instructions on page 67.

\* The standard O-Ring material is NBR(e.g. Perbunan®) however FPM(e.g. Viton®) is also available on request (See Page 3).

# Banjo Fittings (ISO/BSP Parallel / Metric Parallel) with DKA-Ring DSWVE-G/M

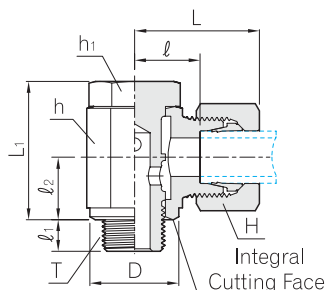

For Tube O.D. up to 15mm

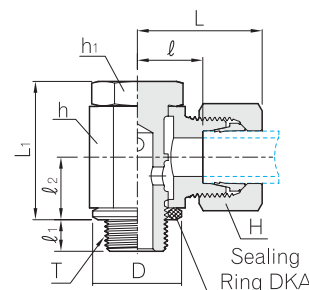

For Tube O.D. 16mm and larger

### for ISO/BSP Paralled

Series	Part No.	Tube O.D.	D	H	h	h <sub>1</sub>	L	L <sub>1</sub>	l	l <sub>1</sub>	l <sub>2</sub>	T	PN(bar)
													C.Steel
L	DSWVE 06L - 01G	6	14.5	14	14	14	25.0	21.0	10.5	6	10.0	G 1/8	160
	DSWVE 08L - 02G	8	18.5	17	19	19	28.0	27.0	13.0	9	13.0	G 1/4	160
	DSWVE 10L - 02G	10	18.5	19	19	19	29.0	27.0	14.0	9	13.0	G 1/4	160
	DSWVE 12L - 03G	12	22.5	22	22	22	30.0	32.0	15.5	9	15.0	G 3/8	100
	DSWVE 15L - 04G	15	26.5	27	27	27	34.0	37.5	19.0	11	18.0	G 1/2	100
	DSWVE 18L - 04G	18	26.0	32	30	27	37.0	44.0	20.5	11	21.5	G 1/2	100
S	DSWVE 22L - 06G	22	32.0	36	36	32	42.0	49.0	25.5	13	24.0	G 3/4	100
	DSWVE 06S - 02G	6	18.5	17	19	19	30.0	27.0	15.0	9	13.0	G 1/4	160
	DSWVE 08S - 02G	8	18.5	19	19	19	30.0	27.0	15.0	9	13.0	G 1/4	160
	DSWVE 10S - 03G	10	22.5	22	22	22	32.0	32.0	16.0	9	15.0	G 3/8	100
	DSWVE 12S - 03G	12	22.5	24	24	24	33.0	37.0	17.0	9	18.0	G 3/8	100
	DSWVE 14S - 04G	14	26.5	27	27	27	38.0	37.0	20.0	11	18.0	G 1/2	100
	DSWVE 16S - 04G	16	26.0	30	30	27	40.0	44.0	21.5	11	21.5	G 1/2	100
DSWVE 20S - 06G	20	32.0	36	36	32	46.0	49.0	24.5	13	24.0	G 3/4	100	

### for Metric Parallel

Series	Part No.	Tube O.D.	D	H	h	h <sub>1</sub>	L	L <sub>1</sub>	l	l <sub>1</sub>	l <sub>2</sub>	T	PN(bar)
													C.Steel
L	DSWVE 06L - M10	6	14.5	14	14	14	25.0	21.5	10.5	6	10.0	M 10 x 1.0	160
	DSWVE 08L - M12	8	17.5	17	17	17	27.0	25.0	12.0	9	12.0	M 12 x 1.5	160
	DSWVE 10L - M14	10	19.5	19	19	19	29.0	27.0	14.0	9	13.0	M 14 x 1.5	160
	DSWVE 12L - M16	12	21.5	22	22	22	30.0	32.0	15.5	9	15.0	M 16 x 1.5	100
	DSWVE 15L - M18	15	23.5	27	24	24	33.0	37.5	17.5	19	18.0	M 18 x 1.5	100
	DSWVE 18L - M22	18	27.0	32	30	27	37.0	44.0	20.5	11	21.5	M 22 x 1.5	100
	DSWVE 22L - M26	22	31.0	36	36	32	42.0	49.0	25.5	13	24.0	M 26 x 1.5	100
S	DSWVE 06S - M12	6	17.5	17	17	19	29.0	25.0	14.0	9	12.0	M 12 x 1.5	100
	DSWVE 08S - M14	8	19.5	19	19	19	30.0	27.0	15.0	9	13.0	M 14 x 1.5	100
	DSWVE 10S - M16	10	21.5	22	22	22	32.0	32.0	16.0	9	15.0	M 16 x 1.5	100
	DSWVE 12S - M18	12	23.5	24	24	24	33.0	37.0	17.0	9	18.0	M 18 x 1.5	100
	DSWVE 14S - M20	14	25.5	27	27	27	38.0	37.0	20.0	11	18.0	M 20 x 1.5	100
	DSWVE 16S - M22	16	27.0	30	30	27	40.0	44.0	21.5	11	21.5	M 22 x 1.5	100
	DSWVE 20S - M27	20	32.0	36	36	32	46.0	49.0	24.5	13	24.0	M 27 x 2.0	100

Dimensions are given for approximate length with tightened nut. All dimensions are in millimeters for reference only, subject to change.

## 24° Tube Fittings-DIN 2353 & ISO 8434-1

### High Pressure Banjo Fittings (BSP Paralled / Metric Paralled) with DKA-Ring DWH-G/M

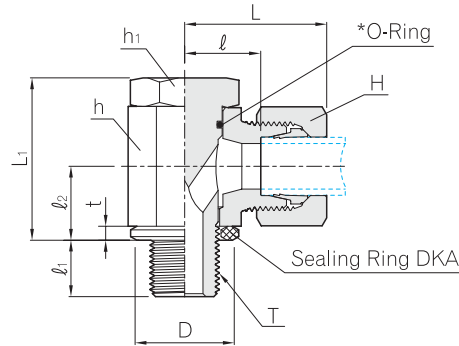

#### for BSP Paralled

Series	Part No.	Tube O.D.	D	H	h	h <sub>1</sub>	L	L <sub>1</sub>	l	l <sub>1</sub>	l <sub>2</sub>	t	T G(PF)	PN(bar)		
														Steel	SS316	BRASS
L	DWH 06L - 01G	6	14	14	17	17	27	24	12.0	8	10.5	2.5	1/8	250	250	160
	DWH 08L - 02G	8	18	17	22	19	29	30	14.5	12	14.0	3.0	1/4	250	250	160
	DWH 10L - 02G	10	18	19	22	19	30	30	15.5	12	14.0	3.0	1/4	250	250	160
	DWH 12L - 03G	12	22	22	27	24	33	36	18.0	12	16.5	3.0	3/8	250	250	160
	DWH 15L - 04G	15	26	27	32	30	37	45	21.5	14	21.5	4.5	1/2	250	250	160
	DWH 18L - 04G	18	26	32	32	30	37	45	21.0	14	21.5	4.5	1/2	250	250	160
	DWH 22L - 06G	22	32	36	41	36	44	53	27.5	16	24.0	3.5	3/4	160	160	
	DWH 28L - 08G	28	39	41	50	46	49	66	32.0	18	30.5	3.5	1	160	160	
	DWH 35L - 10G	35	49	50	60	55	58	76	36.0	20	35.5	3.5	1 1/4	160	160	
DWH 42L - 12G	42	55	60	70	60	63	87	40.5	22	40.5	3.5	1 1/2	160	160		
S	DWH 06S - 02G	6	18	17	22	19	31	30	16.5	12	14.0	3.0	1/4	315	315	200
	DWH 08S - 02G	8	18	19	22	19	31	30	16.5	12	14.0	3.0	1/4	315	315	200
	DWH 10S - 03G	10	22	22	27	24	35	36	18.5	12	16.5	3.0	3/8	315	315	200
	DWH 12S - 03G	12	22	24	27	24	35	36	18.5	12	16.5	3.0	3/8	315	315	200
	DWH 16S - 04G	16	26	30	32	30	40	45	22.0	14	21.5	4.5	1/2	315	315	
	DWH 20S - 06G	20	32	36	41	36	48	53	26.5	16	24.0	3.5	3/4	160	160	
	DWH 25S - 08G	25	39	46	50	46	56	66	31.5	18	30.5	3.5	1	160	160	
	DWH 30S - 10G	30	49	50	60	55	64	76	37.0	20	34.5	3.5	1 1/4	160	160	
	DWH 38S - 12G	38	55	60	70	60	72	87	41.5	22	40.5	3.5	1 1/2	160	160	

#### for Metric Paralled

Series	Part No.	Tube O.D.	D	H	h	h <sub>1</sub>	L	L <sub>1</sub>	l	l <sub>1</sub>	l <sub>2</sub>	t	T M(Metric)	PN(bar)	
														Steel	SS316
L	DWH 06L - M10	6	14	14	17	17	27	24.0	12.0	8	10.5	2.5	M 10 x 1	250	250
	DWH 08L - M12	8	17	17	22	19	29	30.0	14.5	12	14.0	3.0	M 12 x 1.5	250	250
	DWH 10L - M14	10	19	19	22	19	30	30.0	15.5	12	14.0	3.0	M 14 x 1.5	250	250
	DWH 12L - M16	12	21	22	27	24	33	36.0	18.0	12	16.5	3.0	M 16 x 1.5	250	250
	DWH 15L - M18	15	23	27	30	27	36	39.5	20.5	12	18.5	3.0	M 18 x 1.5	250	250
	DWH 18L - M22	18	27	32	32	30	37	45.0	21.0	14	21.5	4.5	M 22 x 1.5	250	250
	DWH 22L - M26	22	31	36	41	36	44	53.0	27.5	16	24.0	3.5	M 26 x 1.5	160	160
	DWH 28L - M33	28	39	41	50	46	49	66.0	32.0	18	30.5	3.5	M 33 x 2	160	160
	DWH 35L - M42	35	49	50	60	55	58	76.0	36.0	20	35.5	3.5	M 42 x 2	160	160
DWH 42L - M48	42	55	60	70	60	63	87.0	40.5	22	40.5	3.5	M 48 x 2	160	160	
S	DWH 06S - M12	6	17	17	22	19	31	30.0	16.5	12	14.0	3.0	M 12 x 1.5	315	315
	DWH 08S - M14	8	19	19	22	19	31	30.0	16.5	12	14.0	3.0	M 14 x 1.5	315	315
	DWH 10S - M16	10	21	22	27	24	35	36.0	18.5	12	16.5	3.0	M 16 x 1.5	315	315
	DWH 12S - M18	12	23	24	30	27	35	39.5	20.0	12	18.5	3.0	M 18 x 1.5	315	315
	DWH 16S - M22	16	27	30	32	30	40	45.0	22.0	14	21.5	4.5	M 22 x 1.5	315	315
	DWH 20S - M27	20	32	36	41	36	48	53.0	26.5	16	24.0	3.5	M 27 x 2	160	160
	DWH 25S - M33	25	39	46	50	46	56	66.0	31.5	18	30.5	3.5	M 33 x 2	160	160
	DWH 30S - M42	30	49	50	60	55	64	76.0	37.0	20	35.5	3.5	M 42 x 2	160	160
	DWH 38S - M48	38	55	60	70	60	72	87.0	41.5	22	40.5	3.5	M 48 x 2	160	160

Dimensions are given for approximate length with tightened nut. All dimensions are in millimeters for reference only, subject to change.

\* The standard O-Ring material is NBR(e.g. Perbunan®) however FPM(e.g. Viton®) is also available on request (See Page 3).



# High Pressure Banjo Fittings (ISO/BSP Parallel / Metric Parallel)

## DTH-G/M

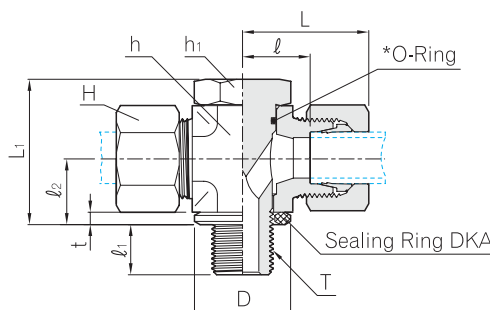

### for ISO/BSP Parallel

Series	Part No.	Tube O.D.	D	H	h	h <sub>1</sub>	L	L <sub>1</sub>	l	l <sub>1</sub>	l <sub>2</sub>	t	T	PN(bar)	
														C.Steel	SS316
L	DTH 06L - 01G	6	14	14	17	17	27	24	12.0	8	10.5	2.5	G 1/8	250	250
	DTH 08L - 02G	8	18	17	22	19	29	30	14.5	12	14.0	3.0	G 1/4	250	250
	DTH 10L - 02G	10	18	19	22	19	30	30	15.5	12	14.0	3.0	G 1/4	250	250
	DTH 12L - 03G	12	22	22	27	24	33	36	18.0	12	16.5	3.0	G 3/8	250	250
	DTH 15L - 04G	15	26	27	32	30	37	45	21.5	14	21.5	4.5	G 1/2	250	250
	DTH 18L - 04G	18	26	32	32	30	37	45	21.0	14	21.5	4.5	G 1/2	250	250
	DTH 22L - 06G	22	32	36	41	36	44	53	27.5	16	24.0	3.5	G 3/4	160	160
	DTH 28L - 08G	28	39	41	50	46	49	66	32.0	18	30.5	3.5	G 1	160	160
	DTH 35L - 10G	35	49	50	60	55	58	76	36.0	20	35.5	3.5	G 1 1/4	160	160
DTH 42L - 12G	42	55	60	70	60	63	87	40.5	22	40.5	3.5	G 1 1/2	160	160	
S	DTH 06S - 02G	6	18	17	22	19	31	30	16.5	12	14.0	3.0	G 1/4	315	315
	DTH 08S - 02G	8	18	19	22	19	31	30	16.5	12	14.0	3.0	G 1/4	315	315
	DTH 10S - 03G	10	22	22	27	24	35	36	18.5	12	16.5	3.0	G 3/8	315	315
	DTH 12S - 03G	12	22	24	27	24	35	36	18.5	12	16.5	3.0	G 3/8	315	315
	DTH 16S - 04G	16	26	30	32	30	40	45	22.0	14	21.5	4.5	G 1/2	315	315
	DTH 20S - 06G	20	32	36	41	36	48	53	26.5	16	24.0	3.5	G 3/4	160	160
	DTH 25S - 08G	25	39	46	50	46	56	66	31.5	18	30.5	3.5	G 1	160	160
	DTH 30S - 10G	30	49	50	60	55	64	76	37.0	20	35.5	3.5	G 1 1/4	160	160
	DTH 38S - 12G	38	55	60	70	60	72	87	41.5	22	40.5	3.5	G 1 1/2	160	160

### for Metric Parallel

Series	Part No.	Tube O.D.	D	H	h	h <sub>1</sub>	L	L <sub>1</sub>	l	l <sub>1</sub>	l <sub>2</sub>	t	T	PN(bar)	
														C.Steel	SS316
L	DTH 06L - M10	6	14	14	17	17	27	24.0	12.0	8	10.5	2.5	M 10 x 1.0	250	250
	DTH 08L - M12	8	17	17	22	19	29	30.0	14.5	12	14.0	3.0	M 12 x 1.5	250	250
	DTH 10L - M14	10	19	19	22	19	30	30.0	15.5	12	14.0	3.0	M 14 x 1.5	250	250
	DTH 12L - M16	12	21	22	27	24	33	36.0	18.0	12	16.5	3.0	M 16 x 1.5	250	250
	DTH 15L - M18	15	23	27	30	27	36	39.5	20.5	12	18.5	3.0	M 18 x 1.5	250	250
	DTH 18L - M22	18	27	32	32	30	37	45.0	21.0	14	21.5	4.5	M 22 x 1.5	250	250
	DTH 22L - M26	22	31	36	41	36	44	53.0	27.5	16	24.0	3.5	M 26 x 1.5	160	160
	DTH 28L - M33	28	39	41	50	46	49	66.0	32.0	18	30.5	3.5	M 33 x 2.0	160	160
	DTH 35L - M42	35	49	50	60	55	58	76.0	36.0	20	35.5	3.5	M 42 x 2.0	160	160
DTH 42L - M48	42	55	60	70	60	63	87.0	40.5	22	40.5	3.5	M 48 x 2.0	160	160	
S	DTH 06S - M12	6	17	17	22	19	31	30.0	16.5	12	14.0	3.0	M 12 x 1.5	315	315
	DTH 08S - M14	8	19	19	22	19	31	30.0	16.5	12	14.0	3.0	M 14 x 1.5	315	315
	DTH 10S - M16	10	21	22	27	24	35	36.0	18.5	12	16.5	3.0	M 16 x 1.5	315	315
	DTH 12S - M18	12	23	24	30	27	36	39.5	20.0	12	18.5	3.0	M 18 x 1.5	315	315
	DTH 16S - M22	16	27	30	32	30	40	45.0	22.0	14	21.5	4.5	M 22 x 1.5	315	315
	DTH 20S - M27	20	32	36	41	36	48	53.0	26.5	16	24.0	3.5	M 27 x 2.0	160	160
	DTH 25S - M33	25	39	46	50	46	56	66.0	31.5	18	30.5	3.5	M 33 x 2.0	160	160
	DTH 30S - M42	30	49	50	60	55	64	76.0	37.0	20	35.5	3.5	M 42 x 2.0	160	160
	DTH 38S - M48	38	55	60	70	60	72	87.0	41.5	22	40.5	3.5	M 48 x 2.0	160	160

Dimensions are given for approximate length with tightened nut. All dimensions are in millimeters for reference only, subject to change.  
 \* The standard O-Ring material is NBR(e.g. Perbunan®) however FPM(e.g. Viton®) is also available on request (See Page 3).

## 24° Tube Fittings-DIN 2353 & ISO 8434-1

### Throttlefree Banjo Fittings (ISO/BSP / Metric Parallel) with DKAZ-Ring DSVW-G/M

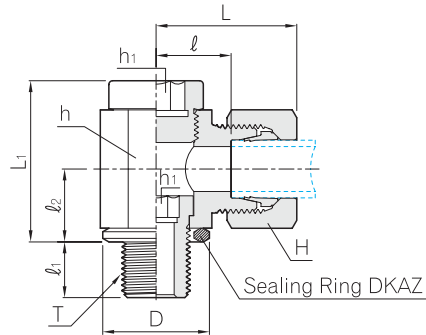
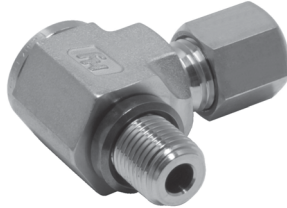

#### for ISO/BSP Parallel

Series	Part No.	Tube O.D.	D	H	h	h <sub>1</sub>	L	L <sub>1</sub>	l	l <sub>1</sub>	l <sub>2</sub>	T	PN(bar) C.Steel
L	DSVW 06L - 01G	6	14	14	19	6	27	24	12,5	8	12	G 1/8	160
	DSVW 08L - 02G	8	18	17	22	8	29	30	14,5	12	16	G 1/4	160
	DSVW 10L - 02G	10	18	19	22	8	30	30	15,5	12	16	G 1/4	100
	DSVW 12L - 03G	12	22	22	27	10	33	37	18,0	12	18	G 3/8	100
	DSVW 15L - 04G	15	26	27	32	12	37	42	22,0	14	21	G 1/2	100
	DSVW 18L - 04G	18	26	32	36	12	38	46	21,5	14	23	G 1/2	100
	DSVW 22L - 06G	22	32	36	46	17	45	58	28,5	16	28	G 3/4	100
	DSVW 28L - 08G	28	39	41	50	22	48	64	31,5	18	32	G 1	100
	DSVW 35L - 10G	35	49	50	60	27	57	76	35,5	20	37	G 1 1/4	63
DSVW 42L - 12G	42	55	60	65	32	63	85	40,0	22	42	G 1 1/2	63	
S	DSVW 06S - 02G	6	18	17	22	8	31	30	16,5	12	16	G 1/4	160
	DSVW 08S - 02G	8	18	19	22	8	31	30	16,5	12	16	G 1/4	160
	DSVW 10S - 03G	10	22	22	27	10	35	37	18,5	12	18	G 3/8	100
	DSVW 12S - 03G	12	22	24	27	10	35	37	18,5	12	18	G 3/8	100
	DSVW 14S - 04G	14	26	27	32	12	41	42	23,0	14	21	G 1/2	100
	DSVW 16S - 04G	16	26	30	36	12	41	46	22,5	14	23	G 1/2	100
	DSVW 20S - 06G	20	32	36	46	17	49	58	27,5	16	28	G 3/4	100
	DSVW 25S - 08G	25	39	46	50	22	55	64	31,0	18	32	G 1	100
	DSVW 30S - 10G	30	49	50	60	27	63	76	36,5	20	37	G 1 1/4	63
DSVW 38S - 12G	38	55	60	70	32	72	85	41,0	22	42	G 1 1/2	63	

#### for Metric Parallel

Series	Part No.	Tube O.D.	D	H	h	h <sub>1</sub>	L	L <sub>1</sub>	l	l <sub>1</sub>	l <sub>2</sub>	T	PN(bar) C.Steel
L	DSVW 06L - M10	6	14	14	19	6	27	24	12,5	8	12	M 10 x 1,0	160
	DSVW 08L - M12	8	17	17	22	6	29	30	14,5	12	15	M 12 x 1,5	160
	DSVW 10L - M14	10	19	19	22	8	30	30	15,5	12	16	M 14 x 1,5	100
	DSVW 12L - M16	12	21	22	27	10	33	37	18,0	12	18	M 16 x 1,5	100
	DSVW 15L - M18	15	23	27	30	12	36	40	21,0	12	20	M 18 x 1,5	100
	DSVW 18L - M22	18	27	32	36	14	38	46	21,5	14	23	M 22 x 1,5	100
	DSVW 22L - M26	22	31	36	41	17	42	51	26,5	16	25	M 26 x 1,5	100
	DSVW 28L - M33	28	39	41	50	22	48	64	31,5	18	32	M 33 x 2,0	100
	DSVW 35L - M42	35	49	50	60	27	57	76	35,5	20	37	M 42 x 2,0	63
DSVW 42L - M48	42	55	60	65	32	63	85	40,0	22	42	M 48 x 2,0	63	
S	DSVW 06S - M12	6	17	17	22	6	31	30	16,5	12	15	M 12 x 1,5	160
	DSVW 08S - M14	8	19	19	22	8	31	30	16,5	12	16	M 14 x 1,5	160
	DSVW 10S - M16	10	21	22	27	10	35	37	18,5	12	18	M 16 x 1,5	100
	DSVW 12S - M18	12	23	24	30	12	37	41	20,5	12	20	M 18 x 1,5	100
	DSVW 14S - M20	14	25	27	32	12	41	42	23,0	14	21	M 20 x 1,5	100
	DSVW 16S - M22	16	27	30	36	14	41	46	22,5	14	23	M 22 x 1,5	100
	DSVW 20S - M27	20	32	36	46	17	49	58	27,5	16	28	M 27 x 2,0	100
	DSVW 25S - M33	25	39	46	50	22	55	64	31,0	18	32	M 33 x 2,0	100
	DSVW 30S - M42	30	49	50	60	27	63	76	36,5	20	37	M 42 x 2,0	63
DSVW 38S - M48	38	55	60	70	32	72	85	41,0	22	42	M 48 x 2,0	63	

Dimensions are given for approximate length with tightened nut. All dimensions are in millimeters for reference only, subject to change.

## Throttlefree Banjo Fittings (ISO/BSP / Metric Parallel) with DKAZ-Ring DSVT-G/M

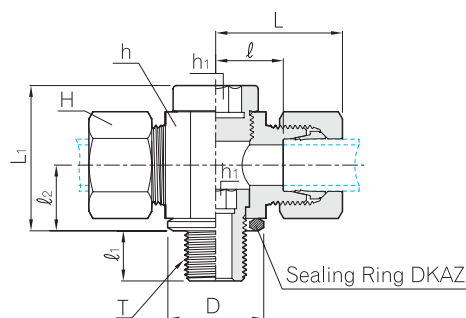

### for ISO/BSP Parallel

Series	Part No.	Tube O.D.	D	H	h	h <sub>1</sub>	L	L <sub>1</sub>	l	l <sub>1</sub>	l <sub>2</sub>	T	PN(bar) C.Steel
L	DSVT 06L - 01G	6	14	14	18	6	27	24	12.0	8	12	G 1/8	160
	DSVT 08L - 02G	8	18	17	22	8	29	30	14.0	12	15	G 1/4	160
	DSVT 10L - 02G	10	18	19	22	8	30	30	15.0	12	15	G 1/4	100
	DSVT 12L - 03G	12	22	22	27	10	32	36	17.5	12	18	G 3/8	100
	DSVT 15L - 04G	15	26	27	30	12	35	40	20.0	14	20	G 1/2	100
	DSVT 18L - 04G	18	26	32	30	12	36	40	19.5	14	20	G 1/2	100
	DSVT 22L - 06G	22	32	36	41	17	43	52	27.0	16	25	G 3/4	100
	DSVT 28L - 08G	28	39	41	46	22	46	58	29.5	18	29	G 1	100
	DSVT 35L - 10G	35	49	50	55	27	55	69	33.0	20	34	G 1 1/4	63
DSVT 42L - 12G	42	55	60	65	32	63	84	40.0	22	41	G 1 1/2	63	
S	DSVT 06S - 02G	6	18	17	22	8	31	30	16.0	12	15	G 1/4	160
	DSVT 08S - 02G	8	18	19	22	8	31	30	16.0	12	15	G 1/4	160
	DSVT 10S - 03G	10	22	22	27	10	34	36	18.0	12	18	G 3/8	100
	DSVT 12S - 03G	12	22	24	27	10	34	36	18.0	12	18	G 3/8	100
	DSVT 14S - 04G	14	26	27	32	12	40	42	22.0	14	21	G 1/2	100
	DSVT 16S - 04G	16	26	30	32	12	40	42	21.5	14	21	G 1/2	100
	DSVT 20S - 06G	20	32	36	46	17	50	57	28.5	16	28	G 3/4	100
	DSVT 25S - 08G	25	39	46	50	22	55	62	31.0	18	31	G 1	100
	DSVT 30S - 10G	30	49	50	60	27	63	74	36.5	20	36	G 1 1/4	63
DSVT 38S - 12G	38	55	60	70	32	72	84	41.0	22	41	G 1 1/2	63	

### for Metric Parallel

Series	Part No.	Tube O.D.	D	H	h	h <sub>1</sub>	L	L <sub>1</sub>	l	l <sub>1</sub>	l <sub>2</sub>	T	PN(bar) C.Steel
L	DSVT 06L - M10	6	14	14	18	6	27	24	12.0	8	12	M 10 x 1.0	160
	DSVT 08L - M12	8	17	17	20	6	28	27	13.0	12	14	M 12 x 1.5	160
	DSVT 10L - M14	10	19	19	22	8	30	30	15.0	12	15	M 14 x 1.5	100
	DSVT 12L - M16	12	21	22	27	10	32	36	17.5	12	18	M 16 x 1.5	100
	DSVT 15L - M18	15	23	27	30	12	35	39	20.0	12	19	M 18 x 1.5	100
	DSVT 18L - M22	18	27	32	32	14	37	41	20.5	14	20	M 22 x 1.5	100
	DSVT 22L - M26	22	31	36	36	17	41	46	24.5	16	22	M 26 x 1.5	100
	DSVT 28L - M33	28	39	41	46	22	46	58	29.5	18	29	M 33 x 2.0	100
	DSVT 35L - M42	35	49	50	55	27	55	69	33.0	20	33	M 42 x 2.0	63
DSVT 42L - M48	42	55	60	65	32	63	84	40.0	22	41	M 48 x 2.0	63	
S	DSVT 06S - M12	6	17	17	20	6	30	27	15.0	12	14	M 12 x 1.5	160
	DSVT 08S - M14	8	19	19	22	8	31	30	16.0	12	15	M 14 x 1.5	160
	DSVT 10S - M16	10	21	22	27	10	34	36	18.0	12	18	M 16 x 1.5	100
	DSVT 12S - M18	12	23	24	30	12	36	39	19.5	12	19	M 18 x 1.5	100
	DSVT 14S - M20	14	25	27	32	12	40	41	22.0	14	20	M 20 x 1.5	100
	DSVT 16S - M22	16	27	30	36	14	42	45	23.5	14	22	M 22 x 1.5	100
	DSVT 20S - M27	20	32	36	46	17	50	58	28.5	16	28	M 27 x 2.0	100
	DSVT 25S - M33	25	39	46	50	22	55	62	31.0	18	31	M 33 x 2.0	100
	DSVT 30S - M42	30	49	50	60	27	63	74	36.5	20	36	M 42 x 2.0	63
DSVT 38S - M48	38	55	60	70	32	72	84	41.0	22	41	M 48 x 2.0	63	

Dimensions are given for approximate length with tightened nut. All dimensions are in millimeters for reference only, subject to change.

Pressure Gauge Connector (ISO/BSP Parallel) with DKI-Ring  
**DGC-G**

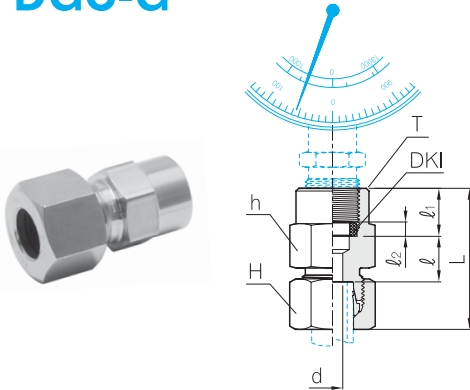

Series	Part No.	Tube O.D.	d	H	h	L	l <sub>1</sub>	l <sub>2</sub>	T	PN(bar)			
										C.Steel	SS316	BRASS	
L	DGC06L - 02G	6	2.5	14	19	37	7.5	14.5	4.5	G 1/4	315	315	200
	DGC08L - 02G	8	5.5	17	19	37	7.5	14.5	4.5	G 1/4	315	315	200
	DGC10L - 02G	10	5.5	19	19	38	8.5	14.5	4.5	G 1/4	315	315	200
	DGC12L - 02G	12	5.5	22	19	38	8.5	14.5	4.5	G 1/4	315	315	200
S	DGC06S - 04G	6	3.5	17	27	46	11.0	20.0	5.0	G 1/2	630	630	400
	DGC08S - 04G	8	3.5	19	27	46	11.0	20.0	5.0	G 1/2	630	630	400
	DGC10S - 04G	10	7.0	22	27	47	10.5	20.0	5.0	G 1/2	630	630	400
	DGC12S - 04G	12	7.0	24	27	47	10.5	20.0	5.0	G 1/2	630	630	400

Dimensions are given approximate length with tightened nut.

Swivel Gauge Adaptor (ISO/BSP Parallel) with cone and DKI-Ring  
**DGE-G**

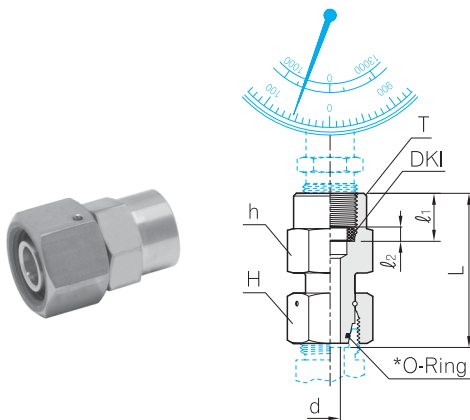

Series	Part No.	Tube O.D.	d	H	h	L	l <sub>1</sub>	l <sub>2</sub>	T	PN(bar)	
										C.Steel	SS316
L	DGE 06L - 02G	6	2.5	14	19	35.5	14.5	4.5	G 1/4	315	315
	DGE 08L - 02G	8	4.0	17	19	35.5	14.5	4.5	G 1/4	315	315
	DGE 10L - 02G	10	5.5	19	19	36.0	14.5	4.5	G 1/4	315	315
	DGE 12L - 02G	12	5.5	22	19	36.0	14.5	4.5	G 1/4	315	315
S	DGE 06S - 04G	6	2.5	17	27	42.5	20.0	5.0	G 1/2	630	630
	DGE 08S - 04G	8	4.0	19	27	43.0	20.0	5.0	G 1/2	630	630
	DGE 10S - 04G	10	6.0	22	27	43.5	20.0	5.0	G 1/2	630	630
	DGE 12S - 04G	12	7.0	24	27	45.0	20.0	5.0	G 1/2	630	630
	DGE 06S - 02G	6	2.5	17	19	35.5	14.5	4.5	G 1/4	630	630
	DGE 08S - 02G	8	4.0	19	19	35.5	14.5	4.5	G 1/4	630	630
	DGE 10S - 02G	10	6.0	22	19	39.0	14.5	4.5	G 1/4	630	630
	DGE 12S - 02G	12	7.0	24	19	39.0	14.5	4.5	G 1/4	630	630

Dimensions are given approximate length with tightened nut.

Please refer to final assembly instructions on page 67.

\* The standard O-Ring material is NBR(e.g. Perbunan®) however FPM(e.g. Viton®) is also available on request (See Page 3).

Gauge Adaptor (ISO/BSP Parallel) with Standpipe and DKI-Ring  
**DGA-G**

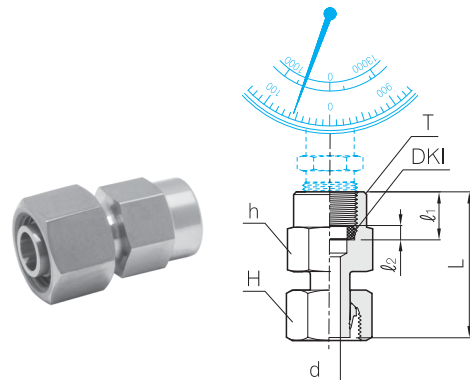

Series	Part No.	Tube O.D.	d	H	h	L	l <sub>1</sub>	l <sub>2</sub>	T	PN(bar)	
										C.Steel	SS316
L	DGA 06L - 02G	6	3.5	14	19	38.0	14.5	4.5	G 1/4	315	315
	DGA 08L - 02G	8	5.5	17	19	38.0	14.5	4.5	G 1/4	315	315
	DGA 10L - 02G	10	7.5	19	19	39.5	14.5	4.5	G 1/4	315	315
	DGA 12L - 02G	12	9.0	22	19	40.5	14.5	4.5	G 1/4	315	315
S	DGA 06S - 04G	6	3.5	17	27	45.0	20.0	5.0	G 1/2	630	630
	DGA 08S - 04G	8	4.5	19	27	45.0	20.0	5.0	G 1/2	630	630
	DGA 10S - 04G	10	6.5	22	27	47.0	20.0	5.0	G 1/2	630	630
	DGA 12S - 04G	12	7.5	24	27	47.5	20.0	5.0	G 1/2	630	630

Please refer to final assembly instructions on page 67.

Tee Test Coupling with threaded Connection DEMA 3-M8

**DGMA**

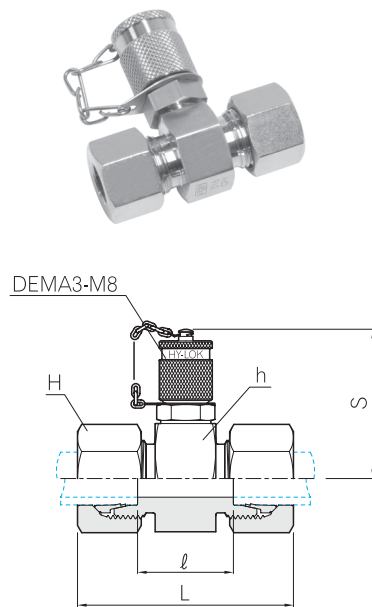

Series	Part No.	Tube O.D.	H	h	L	l	S	PN(bar)	
								C.Steel	SS316
L	DGMA 3 - 06L	6	14	24	50	20.5	45	315	315
	DGMA 3 - 08L	8	17	24	50	20.5	45	315	315
	DGMA 3 - 10L	10	19	24	52	22.5	45	315	315
	DGMA 3 - 12L	12	22	24	52	22.5	45	315	315
	DGMA 3 - 15L	15	27	30	55	24.5	48	315	315
	DGMA 3 - 18L	18	32	32	56	23.5	49	315	315
	DGMA 3 - 22L	22	36	36	60	27.5	51	160	160
	DGMA 3 - 28L	28	41	41	61	27.5	53	160	160
	DGMA 3 - 35L	35	50	46	69	25.5	56	160	160
DGMA 3 - 42L	42	60	55	70	24.5	60	160	160	
S	DGMA 3 - 06S	6	17	24	54	24.5	45	630	630
	DGMA 3 - 08S	8	19	24	54	24.5	45	630	630
	DGMA 3 - 10S	10	22	24	56	23.5	45	630	630
	DGMA 3 - 12S	12	24	24	56	23.5	45	630	630
	DGMA 3 - 14S	14	27	27	62	26.5	46	630	630
	DGMA 3 - 16S	16	30	30	62	25.5	48	400	400
	DGMA 3 - 20S	20	36	36	69	25.5	51	400	400
	DGMA 3 - 25S	25	46	41	75	26.5	53	400	400
	DGMA 3 - 30S	30	50	46	81	27.5	56	400	400
	DGMA 3 - 38S	38	60	55	90	29.0	60	315	315

Test Coupling with threaded Connection M16

**DEMA**

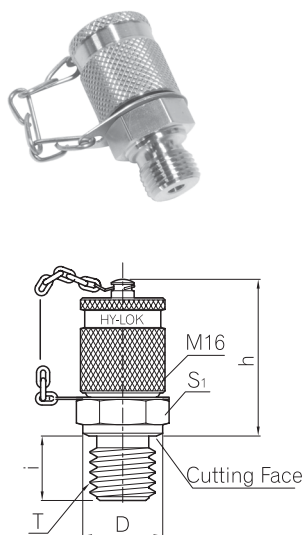

Form B stud end standard  
(Form E stud end available)

Part No.	D	h	i	S <sub>1</sub>	T	PN(bar)
						C.Steel
DEMA3 - 01G	14	36	8	17	G 1/8	400
DEMA3 - 02G	18	36	10	19	G 1/4	400
DEMA3 - 03G	22	36	12	22	G 3/8	400
DEMA3 - 04G	26	36	14	27	G 1/2	400
DEMA3 - M10	14	36	8	17	M 10 x 1	400
DEMA3 - M12	17	36	12	17	M 12 x 1.5	400
DEMA3 - M14	19	36	12	19	M 14 x 1.5	400
DEMA3 - M16	21	36	12	22	M 16 x 1.5	400

Dimensions are given for approximate length with tightened nut, All dimensions are in millimeters for reference only, subject to change.

## 24° Tube Fittings-DIN 2353 & ISO 8434-1

### Welding Connector DAS

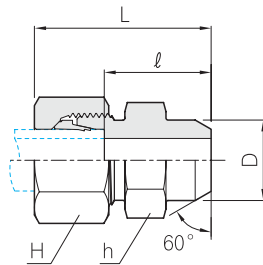

Series	Part No.	Tube O.D.	D	H	h	L	l	PN(bar)	
								Steel	SS316
L	DAS - 06L	6	10	14	12	29	14.0	315	315
	DAS - 08L	8	12	17	14	31	16.0	315	315
	DAS - 10L	10	14	19	17	33	18.0	315	315
	DAS - 12L	12	16	22	19	33	18.0	315	315
	DAS - 15L	15	19	27	22	37	22.0	315	315
	DAS - 18L	18	22	32	27	40	23.5	315	315
	DAS - 22L	22	27	36	32	45	28.5	160	160
	DAS - 28L	28	32	41	41	47	30.5	160	160
	DAS - 35L	35	40	50	46	54	32.5	160	160
DAS - 42L	42	46	60	55	58	35.0	160	160	
S	DAS - 06S	6	11	17	14	34	19.0	630	630
	DAS - 08S	8	13	19	17	36	21.0	630	630
	DAS - 10S	10	15	22	19	39	22.5	630	630
	DAS - 12S	12	17	24	22	41	24.5	630	630
	DAS - 14S	14	19	27	24	45	27.0	630	630
	DAS - 16S	16	21	30	27	45	26.5	400	400
	DAS - 20S	20	26	36	32	51	29.5	400	400
	DAS - 25S	25	31	46	41	56	32.0	400	400
	DAS - 30S	30	36	50	46	62	35.5	400	400
DAS - 38S	38	44	60	55	69	38.0	315	315	

### Welding Connector with DAK DASK

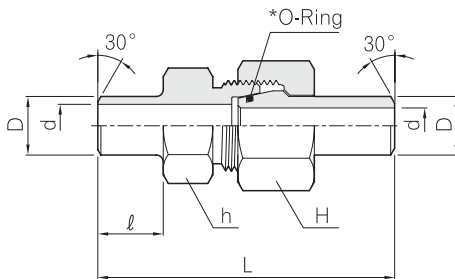

Series	Part No.	Tube O.D. D	d	H	h	L	l	PN(bar)	
								Steel	SS316
S	DASK 10 x 1.0	10	8	22	19	58.0	10.0	249	242
	DASK 10 x 1.5	10	7	22	19	58.0	10.0	358	349
	DASK 10 x 2.0	10	6	22	19	58.0	10.0	460	447
	DASK 12 x 1.5	12	9	24	22	65.0	15.0	305	297
	DASK 12 x 2.0	12	8	24	22	65.0	15.0	393	383
	DASK 12 x 2.5	12	7	24	22	65.0	15.0	476	463
	DASK 16 x 1.5	16	13	30	27	74.5	16.5	234	228
	DASK 16 x 2.0	16	12	30	27	74.5	16.5	305	297
	DASK 16 x 2.5	16	11	30	27	74.5	16.5	372	362
	DASK 16 x 3.0	16	10	30	27	74.5	16.5	400	400
	DASK 20 x 2.0	20	16	36	32	84.0	19.0	249	242
	DASK 20 x 2.5	20	15	36	32	84.0	19.0	305	297
	DASK 20 x 3.0	20	14	36	32	84.0	19.0	358	349
	DASK 20 x 4.0	20	12	36	32	84.0	19.0	400	400
	DASK 25 x 3.0	25	19	46	41	94.5	19.5	294	286
	DASK 25 x 4.0	25	17	46	41	94.5	19.5	379	369
	DASK 25 x 5.0	25	15	46	41	94.5	19.5	400	400
	DASK 30 x 3.0	30	24	50	46	102.0	23.0	249	242
	DASK 30 x 4.0	30	22	50	46	102.0	23.0	323	314
	DASK 30 x 5.0	30	20	50	46	102.0	23.0	393	383
DASK 30 x 6.0	30	18	50	46	102.0	23.0	400	400	
DASK 38 x 4.0	38	30	60	55	111.0	23.0	261	254	
DASK 38 x 5.0	38	28	60	55	111.0	23.0	315	311	
DASK 38 x 6.0	38	26	60	55	111.0	23.0	315	315	
DASK 38 x 7.0	38	24	60	55	111.0	23.0	315	315	

All dimensions are in millimeters for reference only, subject to change.

\* The standard O-Ring material is NBR(e.g. Perbunan®) however FPM(e.g. Viton®) is also available on request (See Page 3).

Max. Pressure ratings are based on carbon steel, and the pressure rating of the stainless steel refers to page 5.

Welding Nipple with \*O-Ring  
DAK

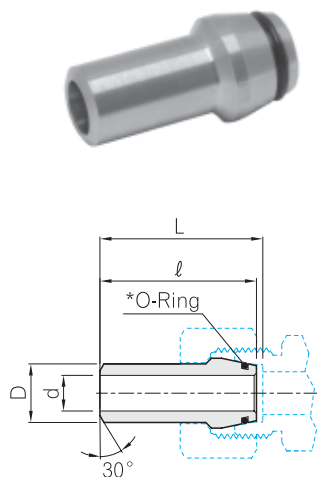

Series	Part No.	Tube O.D. D	d <sup>†</sup>	L	l	PN(bar)	
						Steel	SS316
L/S	DAK 10 x 1.0	10	8	35.5	33.0	249	242
	DAK 10 x 1.5	10	7	35.5	33.0	358	349
	DAK 10 x 2.0	10	6	35.5	33.0	460	447
	DAK 12 x 1.5	12	9	35.5	33.0	305	297
	DAK 12 x 2.0	12	8	35.5	33.0	393	383
	DAK 12 x 2.5	12	7	35.5	33.0	476	463
S	DAK 16 x 1.5	16	13	42.5	39.0	234	228
	DAK 16 x 2.0	16	12	42.5	39.0	305	297
	DAK 16 x 2.5	16	11	42.5	39.0	372	362
	DAK 16 x 3.0	16	10	42.5	39.0	400	400
	DAK 20 x 2.0	20	16	47.5	43.5	249	242
	DAK 20 x 2.5	20	15	47.5	43.5	305	297
	DAK 20 x 3.0	20	14	47.5	43.5	358	349
	DAK 20 x 4.0	20	12	47.5	43.5	400	400
	DAK 25 x 3.0	25	19	55.0	49.5	294	286
	DAK 25 x 4.0	25	17	55.0	49.5	379	369
	DAK 25 x 5.0	25	15	55.0	49.5	400	400
	DAK 30 x 3.0	30	24	58.5	51.5	249	242
	DAK 30 x 4.0	30	22	58.5	51.5	323	314
	DAK 30 x 5.0	30	20	58.5	51.5	393	383
	DAK 30 x 6.0	30	18	58.5	51.5	400	400
	DAK 38 x 4.0	38	30	66.0	56.5	261	254
	DAK 38 x 5.0	38	28	66.0	56.5	315	315
DAK 38 x 6.0	38	26	66.0	56.5	315	315	
DAK 38 x 7.0	38	24	66.0	56.5	315	315	

Reducing Welding Nipple with \*O-Ring  
DAK

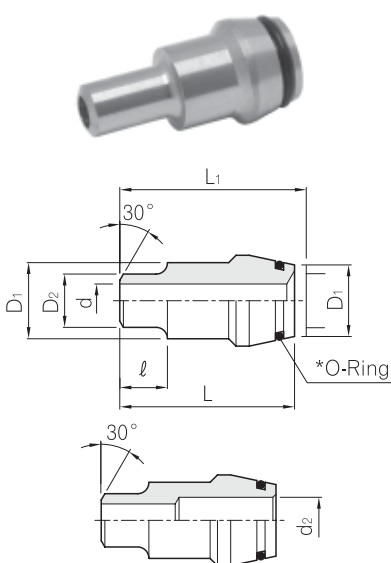

Series	Part No.	Tube O.D.		d <sup>†</sup>	d <sub>2</sub>	L <sub>1</sub>	L	l	PN(bar)	
		D <sub>1</sub>	D <sub>2</sub>						Steel	SS316
L/S	DAK 1006 x 1.5	10	6	3	5	37.5	35.0	12	528	539
	DAK 1008 x 2.0	10	8	4	-	37.5	35.0	12	528	539
	DAK 1208 x 2.0	12	8	4	6	37.5	35.0	14	528	539
	DAK 1210 x 1.5	12	10	7	-	37.5	35.0	14	358	349
S	DAK 1612 x 2.5	16	12	7	-	46.5	43.0	15	400	400
	DAK 2012 x 2.5	20	12	7	-	51.5	47.5	15	400	400
	DAK 2016 x 3.0	20	16	10	-	53.5	49.5	17	400	400
	DAK 2516 x 3.0	25	16	10	-	56.5	51.0	17	400	400
	DAK 2520 x 4.0	25	20	12	-	59.5	54.0	20	400	400
	DAK 3016 x 2.0	30	16	12	-	67.0	60.0	17	305	297
	DAK 3020 x 2.5	30	20	15	-	70.0	63.0	20	305	297
	DAK 3025 x 3.0	30	25	19	-	70.0	63.0	20	294	286
	DAK 3816 x 2.0	38	16	12	-	79.0	69.5	17	305	297
	DAK 3820 x 2.5	38	20	15	-	82.0	72.5	20	305	297
	DAK 3825 x 3.0	38	25	19	-	82.0	72.5	20	294	286
	DAK 3830 x 4.0	38	30	22	-	82.0	72.5	20	315	315

All dimensions are in millimeters for reference only, subject to change.

\* The standard O-Ring material is NBR(e.g. Perbunan®) however FPM(e.g. Viton®) is also available on request (See Page 3).

Max. Pressure ratings are based on carbon steel, and the pressure rating of the stainless steel refers to page 5.

† Mark is base on welding thickness.

## Installation Instruction for Welding Nipple Fittings

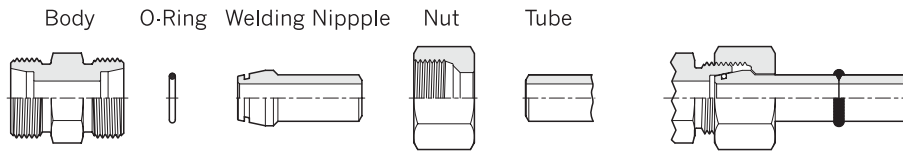

- Step 1. Cut the pipe at right angle by a sawing machine and remove burrs both inside and outside the pipe.
- Step 2. Slide the nut onto the weld nipple.
- Step 3. Weld the tube with nipple and clean welding area around the runs. The tube must be aligned with the welding nipple.
- Step 4. Fit the O-Ring (caution: Do not twist O-ring). Taper, nut and cone must be clean.
- Step 5. Oil the thread on body and the nut.
- Step 6. Screw the nut by hand then, tighten fully using a wrench with 1/3 turn.

## Ordering information for Welding Nipple Fittings.

Order No.	Figures	Order No.	Figures
DGV	DU (Without Cutting Ring) + DAK	DGEV	DMC (Without Cutting Ring) + DAK
DWV	DL (Without Cutting Ring) + DAK	DGUV	DMC-ED (Without Cutting Ring) + DAK
DTV	DT (Without Cutting Ring) + DAK	DGEV-R	DMC (Without Cutting Ring) + DAK
DWSEV	DSWVE (Without Cutting Ring) + DAK	DGAI	DFC (Without Cutting Ring) + DAK
		DWEV	DLM (Without Cutting Ring) + DAK



Male Female Adaptor (SIOBSP Parallel)

**H-MFAD**

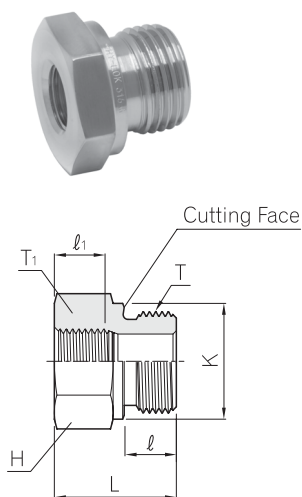

Form B stud end

Part No.	H	K	L	ℓ	ℓ <sub>1</sub>	Male stud T	Female stud T <sub>1</sub>	PN(bar)		
								C.Steel	SS316	BRASS
H-MFAD 6 · 2G	22	22	22.5	12	8	G 3/8	G 1/8	400	400	250
H-MFAD 8 · 2G	27	26	24.0	14	8	G 1/2	G 1/8	400	400	250
H-MFAD 8 · 4G	27	26	24.0	14	12	G 1/2	G 1/4	315	315	200
H-MFAD 12 · 4G	32	32	26.0	16	12	G 3/4	G 1/4	315	315	200
H-MFAD 12 · 6G	32	32	26.0	16	12	G 3/4	G 3/8	315	315	200
H-MFAD 16 · 4G	41	39	29.0	18	12	G 1	G 1/4	315	315	
H-MFAD 16 · 6G	41	39	29.0	18	12	G 1	G 3/8	315	315	200
H-MFAD 16 · 8G	41	39	29.0	18	14	G 1	G 1/2	315	315	200
H-MFAD 20 · 8G	50	49	32.0	20	14	G 1 1/4	G 1/2	160	160	100
H-MFAD 20 · 12G	50	49	32.0	20	16	G 1 1/4	G 3/4	160	160	100
H-MFAD 24 · 8G	55	55	36.0	22	14	G 1 1/2	G 1/2	160	160	100
H-MFAD 24 · 12G	55	55	36.0	22	16	G 1 1/2	G 3/4	160	160	100
H-MFAD 24 · 16G	55	55	36.0	22	18	G 1 1/2	G 1	160	160	100

Male Female Adaptor (ISO/BSP Parallel)

**H-MFAE**

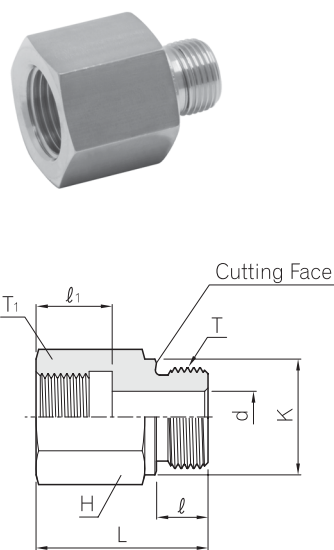

Form B stud end

Part No.	d	H	K	L	ℓ	ℓ <sub>1</sub>	Male stud T	Female stud T <sub>1</sub>	PN(bar)		
									C.Steel	SS316	BRASS
H-MFAE 2 · 4G	4	19	14	31	8	17.0	G 1/8	G 1/4	400	400	250
H-MFAE 2 · 6G	4	24	14	32	8	17.0	G 1/8	G 3/8	400	400	250
H-MFAE 4 · 2G	5	19	18	28	12	12.0	G 1/4	G 1/8	400	400	250
H-MFAE 4 · 6G	5	24	18	36	12	17.0	G 1/4	G 3/8	400	400	250
H-MFAE 4 · 8G	5	30	18	40	12	20.0	G 1/4	G 1/2	400	400	250
H-MFAE 4 · 12G	5	36	18	43	12	22.0	G 1/4	G 3/4	315	315	200
H-MFAE 6 · 4G	8	22	22	36	12	17.0	G 3/8	G 1/4	400	400	250
H-MFAE 6 · 8G	8	30	22	41	12	20.0	G 3/8	G 1/2	400	400	250
H-MFAE 6 · 12G	8	36	22	44	12	22.0	G 3/8	G 3/4	315	315	200
H-MFAE 8 · 6G	12	27	26	36	14	17.0	G 1/2	G 3/8	315	315	200
H-MFAE 8 · 12G	12	36	26	46	14	22.0	G 1/2	G 3/4	315	315	200
H-MFAE 8 · 16G	12	41	26	49	14	24.5	G 1/2	G 1	315	315	200
H-MFAE 8 · 20G	10	55	26	53	14	26.5	G 1/2	G 1 1/4	160	160	
H-MFAE 12 · 8G	16	32	32	41	16	20.0	G 3/4	G 1/2	315	315	200
H-MFAE 12 · 16G	16	41	32	51	16	24.5	G 3/4	G 1	315	315	200
H-MFAE 12 · 20G	16	55	32	55	16	26.5	G 3/4	G 1 1/4	160	160	
H-MFAE 12 · 24G	16	60	32	57	16	28.5	G 3/4	G 1 1/2	160	160	
H-MFAE 16 · 12G	20	41	39	47	18	22.0	G 1	G 3/4	315	315	200
H-MFAE 16 · 20G	20	55	39	57	18	26.5	G 1	G 1 1/4	160	160	100
H-MFAE 16 · 24G	20	60	39	59	18	28.5	G 1	G 1 1/2	160	160	100
H-MFAE 20 · 16G	25	50	49	52	20	24.5	G 1 1/4	G 1	160	160	100
H-MFAE 20 · 24G	25	60	49	60	20	28.5	G 1 1/4	G 1 1/2	160	160	100
H-MFAE 24 · 20G	32	55	55	58	22	26.5	G 1 1/2	G 1 1/4	160	160	100
H-MFAE 32 · 24G	40	70	68	62	24	28.5	G 2	G 1 1/2	160		

Male / Female thread adaptors with metric and NPT thread are available on request. All dimensions are in millimeters for reference only, subject to change.

Male Female Adaptor (ISO/BSP Parallel) with \*ED-Ring  
**H-MFAD-ED**

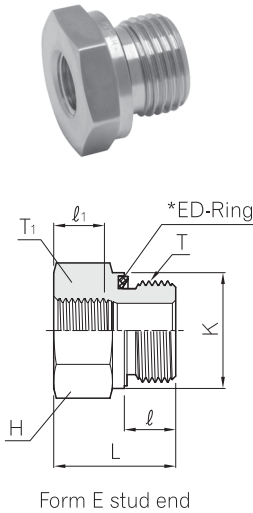

Part No.	H	K	L	ℓ	ℓ <sub>1</sub>	Male stud T	Female stud T <sub>1</sub>	PN(bar)	
								C.Steel	SS316
H-MFAD 6ED - 2G	22	22	22.5	12	8	G 3/8	G 1/8	400	400
H-MFAD 8ED - 2G	27	26	24.0	14	8	G 1/2	G 1/8	400	400
H-MFAD 8ED - 4G	27	26	24.0	14	12	G 1/2	G 1/4	400	400
H-MFAD 12ED - 4G	32	32	26.0	16	12	G 3/4	G 1/4	315	315
H-MFAD 12ED - 6G	32	32	26.0	16	12	G 3/4	G 3/8	315	315
H-MFAD 16ED - 4G	41	39	29.0	18	12	G 1	G 1/4	315	315
H-MFAD 16ED - 6G	41	39	29.0	18	12	G 1	G 3/8	315	315
H-MFAD 16ED - 8G	41	39	29.0	18	14	G 1	G 1/2	315	315
H-MFAD 20ED - 8G	50	49	32.0	20	14	G 1 1/4	G 1/2	315	315
H-MFAD 20ED - 12G	50	49	32.0	20	16	G 1 1/4	G 3/4	315	315
H-MFAD 24ED - 8G	55	55	36.0	22	14	G 1 1/2	G 1/2	250	250
H-MFAD 24ED - 12G	55	55	36.0	22	16	G 1 1/2	G 3/4	250	250
H-MFAD 24ED - 16G	55	55	36.0	22	18	G 1 1/2	G 1	250	250

Male Female Adaptor (ISO/BSP Parallel) with \*ED-Ring  
**H-MFAE-ED**

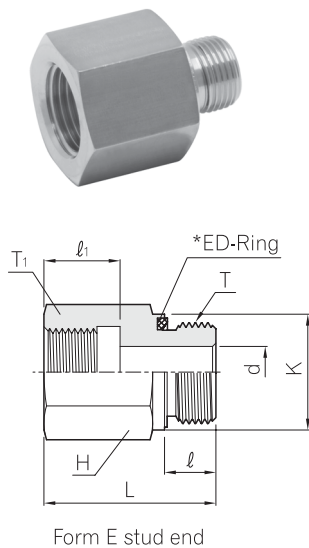

Part No.	d	H	K	L	ℓ	ℓ <sub>1</sub>	Male stud T	Female stud T <sub>1</sub>	PN(bar)	
									C.Steel	SS316
H-MFAE 2ED- 4G	4	19	14	31	8	17.0	G 1/8	G 1/4	400	400
H-MFAE 2ED- 6G	4	24	14	32	8	17.0	G 1/8	G 3/8	400	400
H-MFAE 4ED- 2G	5	19	18	28	12	12.0	G 1/4	G 1/8	400	400
H-MFAE 4ED- 6G	5	24	18	36	12	17.0	G 1/4	G 3/8	400	400
H-MFAE 4ED- 8G	5	30	18	40	12	20.0	G 1/4	G 1/2	400	400
H-MFAE 4ED-12G	5	36	18	43	12	22.0	G 1/4	G 3/4	400	400
H-MFAE 6ED- 4G	8	22	22	36	12	17.0	G 3/8	G 1/4	400	400
H-MFAE 6ED- 8G	8	30	22	41	12	20.0	G 3/8	G 1/2	400	400
H-MFAE 6ED-12G	8	36	22	44	12	22.0	G 3/8	G 3/4	315	315
H-MFAE 8ED- 6G	12	27	26	36	14	17.0	G 1/2	G 3/8	400	400
H-MFAE 8ED-12G	12	36	26	46	14	22.0	G 1/2	G 3/4	315	315
H-MFAE 8ED-16G	12	41	26	49	14	24.5	G 1/2	G 1	315	315
H-MFAE 8ED-20G	10	55	26	53	14	26.5	G 1/2	G 1 1/4	315	315
H-MFAE 12ED- 8G	16	32	32	41	16	20.0	G 3/4	G 1/2	315	315
H-MFAE 12ED-16G	16	41	32	51	16	24.5	G 3/4	G 1	315	315
H-MFAE 12ED-20G	16	55	32	55	16	26.5	G 3/4	G 1 1/4	315	315
H-MFAE 12ED-24G	16	60	32	57	16	28.5	G 3/4	G 1 1/2	250	250
H-MFAE 16ED-12G	20	41	39	47	18	22.0	G 1	G 3/4	315	315
H-MFAE 16ED-20G	20	55	39	57	18	26.5	G 1	G 1 1/4	315	315
H-MFAE 16ED-24G	20	60	39	59	18	28.5	G 1	G 1 1/2	250	250
H-MFAE 20ED-16G	25	50	49	52	20	24.5	G 1 1/4	G 1	315	315
H-MFAE 20ED-24G	25	60	49	60	20	28.5	G 1 1/4	G 1 1/2	250	250
H-MFAE 24ED-20G	32	55	55	58	22	26.5	G 1 1/2	G 1 1/4	250	250
H-MFAE 32ED-24G	40	70	68	62	24	28.5	G 2	G 1 1/2	160	

All dimensions are in millimeters for reference only, subject to change.

\* The standard ED-Ring material is NBR(e.g. perbunan®) however FPM(e.g. Viton®) is also available on Request (See Page3).

## Blanking Plugs with \*ED-Ring for Ports DVSTI-GED/MED

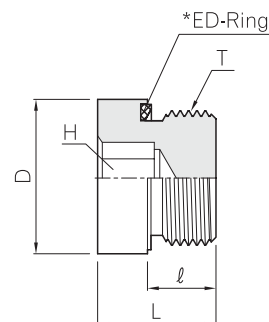

Part No.(M)	Part No.(G)	T	T	D	H	L	l	PN(bar)	
								C.Steel	SS316
DVSTI-M10ED	DVSTI-01GED	M 10 x 1.0	G 1/8	14.0	5	12.0	8	400	400
DVSTI-M12ED	-	M 12 x 1.5	-	17.0	6	17.0	12	400	400
DVSTI-M14ED	DVSTI-02GED	M 14 x 1.5	G 1/4	19.0	6	17.0	12	400	400
DVSTI-M16ED	DVSTI-03GED	M 16 x 1.5	G 3/8	22.0	8	17.0	12	400	400
DVSTI-M18ED	-	M 18 x 1.5	-	23.9	8	17.0	12	400	400
DVSTI-M20ED	-	M 20 x 1.5	-	25.9	10	19.0	14	400	400
DVSTI-M22ED	DVSTI-04GED	M 22 x 1.5	G 1/2	27.0	10	19.0	14	400	400
DVSTI-M26ED	-	M 26 x 1.5	-	31.9	12	21.0	16	400	400
DVSTI-M27ED	DVSTI-06GED	M 27 x 2.0	G 3/4	32.0	12	21.0	16	400	400
DVSTI-M33ED	DVSTI-08GED	M 33 x 2.0	G 1	39.9	17	22.5	16	400	400
DVSTI-M42ED	DVSTI-10GED	M 42 x 2.0	G 1 1/4	49.9	22	22.5	16	315	315
DVSTI-M48ED	DVSTI-12GED	M 48 x 2.0	G 1 1/2	55.0	24	22.5	16	315	315

## Blanking Plugs with \*O-Ring for Ports acc. to ISO 6149 / DIN3852 DVSTI

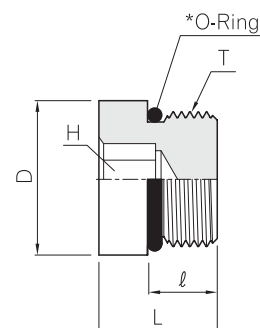

Part No.	T	D	H	L	l	PN(bar) C.Steel
DVSTI - M10	M 10 x 1.0	13	5	14.0	10.0	630
DVSTI - M12	M 12 x 1.5	17	6	16.5	11.5	630
DVSTI - M14	M 14 x 1.5	19	6	16.5	11.5	630
DVSTI - M16	M 16 x 1.5	21	6	18.0	13.0	630
DVSTI - M18	M 18 x 1.5	23	8	19.5	14.5	630
DVSTI - M22	M 22 x 1.5	27	10	20.5	15.5	630
DVSTI - M26	M 26 x 1.5	31	12	21.0	16.0	630
DVSTI - M27	M 27 x 2.0	32	12	24.0	19.0	400
DVSTI - M33	M 33 x 2.0	38	17	25.5	19.0	400
DVSTI - M42	M 42 x 2.0	48	22	26.0	19.5	400

All dimensions are in millimeters for reference only, subject to change.

\* The Standard ED-Ring, O-Ring material is NBR(e.g. Perbunan®) however FPM(e.g. Viton®) is also available on Request (See Page3).

Blanking Plug with \*O-Ring  
**DVKA**

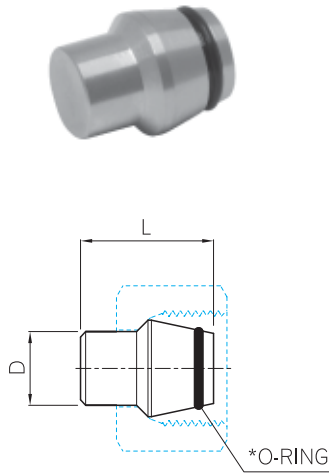

Series	Part No.	Tube O.D D	L	PN(bar)		
				Steel	SS316	BRASS
L/S	DVKA - 06L/S	6	18.5	500	315	200
	DVKA - 08L/S	8	18.5	500	315	200
	DVKA - 10L/S	10	20.0	500	315	200
	DVKA - 12L/S	12	20.5	400	315	200
L	DVKA - 15L	15	20.5	400	315	200
	DVKA - 18L	18	22.5	400	315	200
	DVKA - 22L	22	25.0	250	160	100
	DVKA - 28L	28	25.5	250	160	100
	DVKA - 35L	35	30.0	250	160	100
	DVKA - 42L	42	30.0	250	160	100
S	DVKA - 14S	14	22.5	630	630	400
	DVKA - 16S	16	23.5	630	400	250
	DVKA - 20S	20	28.5	420	400	250
	DVKA - 25S	25	29.0	420	400	250
	DVKA - 30S	30	30.5	420	400	250
	DVKA - 38S	38	33.0	420	315	200

Tube Cap  
**DCA**

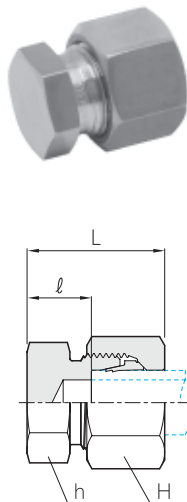

Series	Part No.	Tube O.D	H	h	L	l	PN(bar)	
							Steel	SS316
L	DCA-06L	6	14	12	22	7.0	315	315
	DCA-08L	8	17	14	23	8.0	315	315
	DCA-10L	10	19	17	24	9.0	315	315
	DCA-12L	12	22	19	25	10.0	315	315
	DCA-15L	15	27	24	26	11.0	315	315
	DCA-18L	18	32	27	28	11.5	315	315
	DCA-22L	22	36	32	30	13.5	160	160
	DCA-28L	28	41	41	31	14.5	160	160
	DCA-35L	35	50	46	36	14.5	160	160
DCA-42L	42	60	55	39	16.0	160	160	
S	DCA-06S	6	17	14	26	11.0	630	630
	DCA-08S	8	19	17	28	13.0	630	630
	DCA-10S	10	22	19	29	12.5	630	630
	DCA-12S	12	24	22	31	14.5	630	630
	DCA-14S	14	27	24	34	16.0	630	630
	DCA-16S	16	30	27	34	15.5	400	400
	DCA-20S	20	36	32	39	17.5	400	400
	DCA-25S	25	46	41	44	20.0	400	400
	DCA-30S	30	50	46	47	20.5	400	400
DCA-38S	38	60	55	54	23.0	315	315	

Dimensions are given for approximate length with tightened nut. All dimensions are in millimeters for reference only, subject to change.  
\* The standard O-Ring material is NBR(e.g. Perbunan®) however FPM(e.g. Viton®) is also available on request (See Page 3).

## Tube Insert DIL

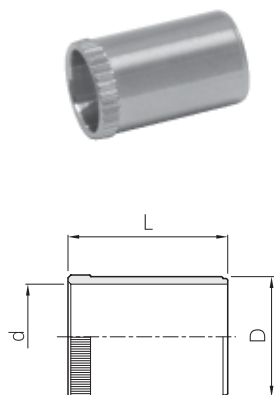

For thin-wall steel and stainless steel and other soft-thin-wall metal tubes.

Part No.	Tube O.D.	Tube I.D.	d	D	L
DIL 6-1	6	4.0	2.6	3.8	15.5
DIL 6-0.75	6	4.5	3.1	4.3	12.5
DIL 6-0.5	6	5.0	3.6	4.8	15.5
DIL 8-1	8	6.0	4.6	5.8	15.5
DIL 10-1.5	10	7.0	5.6	6.8	17.0
DIL 10-1	10	8.0	6.6	7.8	16.5
DIL 12-1.5	12	9.0	7.6	8.8	16.5
DIL 12-1	12	10.0	8.6	9.8	16.5
DIL 15-1.5	15	12.0	10.2	11.8	17.0
DIL 15-1	15	13.0	11.2	12.8	17.0
DIL 16-1	16	14.0	12.2	13.8	17.0
DIL 18-1.5	18	15.0	13.2	14.8	17.5
DIL 18-1	18	16.0	14.2	15.8	17.5
DIL 20-1.5	20	17.0	15.2	16.8	20.0
DIL 20-1	20	18.0	16.2	17.8	22.0
DIL 22-1.5	22	19.0	17.2	18.8	18.0
DIL 22-1	22	20.0	18.2	19.8	18.0
DIL 25-2	25	21.0	19.2	20.8	21.5
DIL 25-1.5	25	22.0	20.2	21.8	23.5
DIL 28-2	28	24.0	22.2	23.8	18.0
DIL 28-1.5	28	25.0	23.2	24.8	18.0
DIL 30-2	30	26.0	24.2	25.8	23.5
DIL 35-2	35	31.0	28.8	30.8	22.5
DIL 38-3	38	32.0	29.8	31.8	26.5
DIL 38-2.5	38	33.0	30.8	32.8	26.5
DIL 42-2	42	38.0	35.8	37.8	23.5

## \*Bulkhead Lock Nut N-

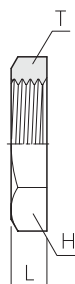

Part No.	Tube O.D.		H	L	T
	Light	Heavy			
N-12 15M 17.0 T 6.0	6	-	17	6	M 12 x 1.5
N-14 15M 19.0 T 6.0	8	6	19	6	M 14 x 1.5
N-16 15M 22.0 T 6.0	10	8	22	6	M 16 x 1.5
N-18 15M 24.0 T 6.0	12	10	24	6	M 18 x 1.5
N-20 15M 27.0 T 6.0	-	12	27	6	M 20 x 1.5
N-22 15M 30.0 T 7.0	15	14	30	7	M 22 x 1.5
N-24 15M 32.0 T 7.0	-	16	32	7	M 24 x 1.5
N-26 15M 36.0 T 8.0	18	-	36	8	M 26 x 1.5
N-30 20M 41.0 T 8.0	22	20	41	8	M 30 x 2
N-36 20M 46.0 T 9.0	28	25	46	9	M 36 x 2
N-42 20M 50.0 T 9.0	-	30	50	9	M 42 x 2
N-45 20M 55.0 T 9.0	35	-	55	9	M 45 x 2
N-52 20M 65.0 T10.0	42	38	65	10	M 52 x 2

\*According to DIN 80705 for bulkhead screw-joint.

Sealing rings for DWH/DTH and DSWVE  
**DKA**



Part No.	External Thread
DKA - 01G	PF 1/8
DKA - 02G	PF 1/4
DKA - 03G	PF 8/8
DKA - 04G	PF 1/2
DKA - 04G x 4.5	PF 1/2
DKA - 06G	PF 3/4
DKA - 08G	PF 1
DKA - 10GM42	PF 1 1/4 / M42 x 2
DKA - 12GM48	PF 1 1/2 / M48 x 2
DKA - M10	M 10 x 1
DKA - M12	M 12 x 1.5
DKA - M14	M 14 x 1.5
DKA - M16	M 16 x 1.5
DKA - M18	M 18 x 1.5
DKA - M20	M 20 x 1.5
DKA - M22	M 22 x 1.5
DKA - M22 x 4.5	M 22 x 1.5
DKA - M26	M 26 x 1.5
DKA - M26 x 3.5	M 26 x 1.5
DKA - M27	M 27 x 2
DKA - M33	M 33 x 2

Sealing rings for DSVW/DSVT  
**DKAZ**



Part No.	External Thread
DKAZ - 01G	PF 1/8
DKAZ - 02G	PF 1/4
DKAZ - 03G	PF 8/8
DKAZ - 04G	PF 1/2
DKAZ - 06G	PF 3/4
DKAZ - 08G	PF 1
DKAZ - 10GM42	PF 1 1/4 / M42 x 2
DKAZ - 12GM48	PF 1 1/2 / M48 x 2
DKAZ - M10	M 10 x 1
DKAZ - M12	M 12 x 1.5
DKAZ - M14	M 14 x 1.5
DKAZ - M16	M 16 x 1.5
DKAZ - M18	M 18 x 1.5
DKAZ - M20	M 20 x 1.5
DKAZ - M22	M 22 x 1.5
DKAZ - M26	M 26 x 1.5
DKAZ - M27	M 27 x 2
DKAZ - M33	M 33 x 2

Sealing rings for DGC  
**DKI**



Part No.	Internal Thread
DKI - 02G	PF 1/4
DKI - 04G	PF 1/2

ED-Ring  
**KP-B-S**



Part No.	For Male Thread	
	Metric	G(PF)
KP - B - S M8	M 8 x 1	-
KP - B - S01G	M 10 x 1	1/8
KP - B - SM12	M 12 x 1.5	-
KP - B - S02G	M 14 x 1.5	1/4
KP - B - SM16	M 16 x 1.5	-
KP - B - S03G	-	3/8
KP - B - SM18	M 18 x 1.5	-
KP - B - SM20	M 20 x 1.5	-
KP - B - S04G	-	1/2
KP - B - SM22	M 22 x 1.5	-
KP - B - S06G	M 26 x 1.5	3/4
	M 27 x 2	3/4
KP - B - S08G	M 33 x 2	1
KP - B - S10G	M 42 x 2	1 1/4
KP - B - S12G	M 48 x 2	1 1/2

O-Ring  
**KP-B-DS**

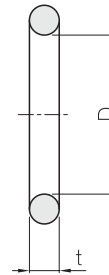

Part No.	D	T
KP - B - DS06	4.0	1.5
KP - B - DS08	6.0	1.5
KP - B - DS10	7.5	1.5
KP - B - DS12	9.0	1.5
KP - B - DS14	10.0	2.0
KP - B - DS16	12.0	2.0
KP - B - DS18	15.0	2.0
KP - B - DS20	16.3	2.4
KP - B - DS22	20.0	2.0
KP - B - DS25	20.3	2.4
KP - B - DS30	25.3	2.4
KP - B - DS28	26.0	2.0
KP - B - DS35	32.0	2.5
KP - B - DS38	33.3	2.4
KP - B - DS42	38.0	2.5

All dimensions are in millimeters for reference only, subject to change.

\* The Standard ED-Ring, O-Ring material is NBR(e.g. Perbunan®) however FPM(e.g. Viton®) is also available on Request (See Page3).

## Tube end Dimension

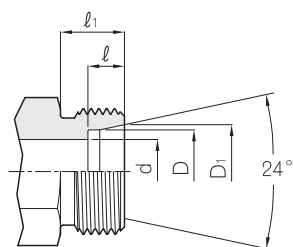
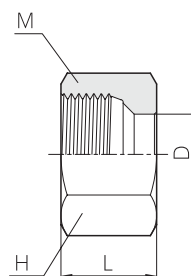
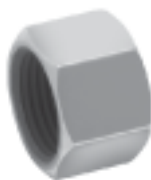
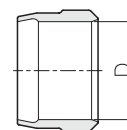
Nut  
DNCutting Ring  
DS

Series	Part No. Nut	Part No. Cutting Ring	Tube O.D	DN Size	D	D <sub>1</sub>	d	H	L	M	ℓ	ℓ <sub>1</sub>
<b>LL</b> Very Light	DN - 04LL	DS - 04LL	4	3	4	5.0	3.0	10	11.5	M 8 x 1.0	4.0	8
	DN - 06LL	DS - 06LL	6	4	6	7.5	4.5	12	12.0	M 10 x 1.0	5.5	8
	DN - 08LL	DS - 08LL	8	6	8	9.5	6.0	14	12.5	M 12 x 1.0	5.5	9
	DN - 10LL	DS - 10LL	10	8	10	11.5	8.0	17	12.5	M 14 x 1.0	6.0	9
	DN - 12LL	DS - 12LL	12	10	12	13.5	10.0	19	13.0	M 16 x 1.0	6.0	9
<b>L</b> Light	DN - 06L	DS - 06	6	4	6	8.1	4.0	14	15.0	M 12 x 1.5	7.0	10
	DN - 08L	DS - 08	8	6	8	10.1	6.0	17	15.0	M 14 x 1.5	7.0	10
	DN - 10L	DS - 10	10	8	10	12.3	8.0	19	16.0	M 16 x 1.5	7.0	11
	DN - 12L	DS - 12	12	10	12	14.3	10.0	22	16.0	M 18 x 1.5	7.0	11
	DN - 15L	DS - 15	15	12	15	17.3	12.0	27	17.5	M 22 x 1.5	7.0	12
	DN - 18L	DS - 18	18	16	18	20.3	15.0	32	18.0	M 26 x 1.5	7.5	12
	DN - 22L	DS - 22	22	20	22	24.3	19.0	36	20.5	M 30 x 2	7.5	14
	DN - 28L	DS - 28	28	25	28	30.3	24.0	41	21.0	M 36 x 2	7.5	14
	DN - 35L	DS - 35	35	32	35	38.0	30.0	50	24.0	M 45 x 2	10.5	16
DN - 42L	DS - 42	42	40	42	45.0	36.0	60	24.0	M 52 x 2	11.0	16	
<b>S</b> Heavy	DN - 06S	DS - 06	6	3	6	8.1	4.0	17	16.5	M 14 x 1.5	7.0	12
	DN - 08S	DS - 08	8	4	8	10.1	5.0	19	16.5	M 16 x 1.5	7.0	12
	DN - 10S	DS - 10	10	6	10	12.3	7.0	22	17.5	M 18 x 1.5	7.5	12
	DN - 12S	DS - 12	12	8	12	14.3	8.0	24	18.0	M 20 x 1.5	7.5	12
	DN - 14S	DS - 14	14	10	14	16.3	10.0	27	20.5	M 22 x 1.5	8.0	14
	DN - 16S	DS - 16	16	12	16	18.3	12.0	30	21.0	M 24 x 1.5	8.5	14
	DN - 20S	DS - 20	20	16	20	22.9	16.0	36	24.0	M 30 x 2	10.5	16
	DN - 25S	DS - 25	25	20	25	27.9	20.0	46	27.0	M 36 x 2	12.0	18
	DN - 30S	DS - 30	30	25	30	33.0	25.0	50	29.5	M 42 x 2	13.5	20
	DN - 38S	DS - 38	38	32	38	41.0	32.0	60	32.5	M 52 x 2	16.0	22

All dimensions are in millimeters for reference only, subject to change.

## 24° Tube Fittings-DIN 2353 & ISO 8434-1

### ■ General Features and Benefits of HyQ Fitting System

High corrosion resistance · Applying advanced heat-treatment method to Retaining Ring.

Sealing · As the main components for elastomeric seal ensures immaculate sealing with no leakage. Thus, the loss of hydraulic system will not be occurred.

Durability · It is not required re-assembly in any environment.

Bite Control · It can be ideally adjusted the depth of bite through a proper design of fitting. Installer can identify a proper depth of bite when securely tighten up the fitting.

Easy assembly · Each components will not be caused the confusion in terms of wrong direction and omission. This can avoid the risk of assembly errors.

Visual Inspection · It can be available for verifying whether preliminary fitting assembly is corrected or not. It is enough that verifying the interval between Retaining Ring and Sealing Ring.

Maintenance · The maintenance and replacement of HyQ Fitting can be performed with only wrench set.

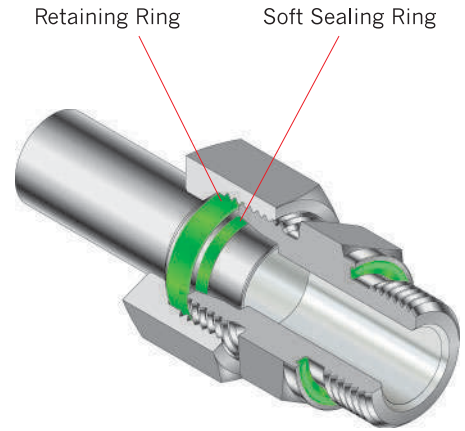

### Functional Soft Sealing Ring DFSR

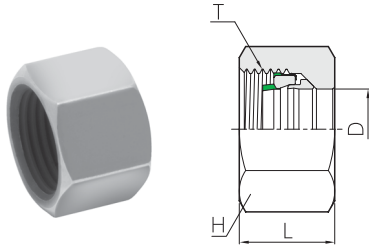

Series	Part No.	Tube O.D.	H	L	T	PN(bar)	
						C.Steel	SS316
L	DFSR-06L	6	14	14.5	M12x1.5	500	315
	DFSR-08L	8	17	14.5	M14x1.5	500	315
	DFSR-10L	10	19	15.5	M16x1.5	500	315
	DFSR-12L	12	22	15.5	M18x1.5	400	315
	DFSR-15L	15	27	17.0	M22x1.5	400	315
	DFSR-18L	18	32	18.0	M26x1.5	400	315
	DFSR-22L	22	36	20.0	M30x2.0	250	160
	DFSR-28L	28	41	21.0	M36x2.0	250	160
	DFSR-35L	35	50	24.0	M45x2.0	250	160
	DFSR-42L	42	60	24.0	M52x2.0	250	160
S	DFSR-06S	6	17	16.5	M14x1.5	800	630
	DFSR-08S	8	19	16.5	M16x1.5	800	630
	DFSR-10S	10	22	17.5	M18x1.5	800	630
	DFSR-12S	12	24	17.5	M20x1.5	630	630
	DFSR-14S	14	27	20.5	M22x1.5	630	630
	DFSR-16S	16	30	20.5	M24x1.5	630	400
	DFSR-20S	20	36	24.0	M30x2.0	420	400
	DFSR-25S	25	46	27.0	M36x2.0	420	400
	DFSR-30S	30	50	29.0	M42x2.0	420	400
	DFSR-38S	38	60	32.5	M52x2.0	420	315

### Soft Sealing Ring (with Retaining Ring) DSRR

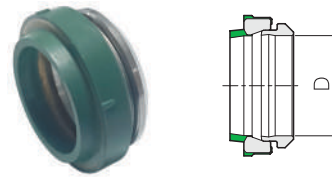

Series	Part No.	Tube O.D.	PN(bar)	
			C.Steel	SS316
L	DSRR-06L	6	500	315
	DSRR-08L	8	500	315
	DSRR-10L	10	500	315
	DSRR-12L	12	400	315
	DSRR-15L	15	400	315
	DSRR-18L	18	400	315
	DSRR-22L	22	250	160
	DSRR-28L	28	250	160
	DSRR-35L	35	250	160
	DSRR-42L	42	250	160
S	DSRR-06S	6	800	630
	DSRR-08S	8	800	630
	DSRR-10S	10	800	630
	DSRR-12S	12	630	630
	DSRR-14S	14	630	630
	DSRR-16S	16	630	400
	DSRR-20S	20	420	400
	DSRR-25S	25	420	400
	DSRR-30S	30	420	400
	DSRR-38S	38	420	315



## DJ - DIN2353 Pre-swaging tool for tube connection.

DJ-DIN2353 is a simple and basic tool for manual preliminary installation.

Directions for use of DJ : Make bite ring safely and properly in tube with inner fitting taper without damages.

All products which use DJ and/or EZYMAT must be connected by pre-assembly.

### ■ Specification :

Materials : Hardened Tool Steel

Size : 4LL · 12LL, 6L · 42L, 6S · 38S.

### ■ Advantages and efficiencies of pre - assembly tools.

1. Marking Notch-Ridge-like lines will be appeared under the precise assembly. Assembly failure factors from incorrect tube cuttings and/or incorrect connections are distinguishable before the final operation.
  2. Flexible - DJ tools are able to be used for guarantee of safe fitting assemblies in which the EZYMAT tools are not used.
  3. Safety - DJ tools prevent the poor assemblies in Stand-Pipe, Hose Fittings and Stainless Tubes.
  4. Efficiency - DJ pre-setting reduces assembly time for Bite Type products. Investment for small equipment provides great and immediate efficiency.
  5. Specialty - DJ tools are designed and produced specially to meet DIN2353 Tube Fitting Standards.
  6. Durability of tools - Assembly tools are being worn away gradually. Cleaning and inspections of the tool are required every 50-times usage (maximum). The failure in assemblies due to the worn tools or no replaced tools at proper time is able to cause risks. Tools endure average 5000-times usage regularly. The maximum durations of tools are able to be accomplished by below instructions.
- ▶ Periodical cleaning and inspection.
  - ▶ Maintenance of cleanness and corrosion resistance.
  - ▶ Proper tube ends de-burring and cleaning.
  - ▶ Selection of operation by proper tools.
  - ▶ Use of designated lubricant.

## DJ

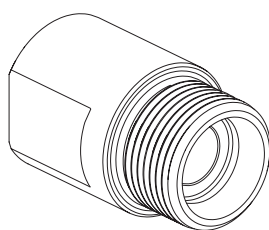

Series	Part No.	Tube O.D.
LL	DJ - 04LL	4
	DJ - 06LL	6
	DJ - 08LL	8
	DJ - 10LL	10
	DJ - 12LL	12
L	DJ - 06L	6
	DJ - 08L	8
	DJ - 10L	10
	DJ - 12L	12
	DJ - 15L	15
	DJ - 18L	18
	DJ - 22L	22
	DJ - 28L	28
	DJ - 35L	35
	DJ - 42L	42
S	DJ - 06S	6
	DJ - 08S	8
	DJ - 10S	10
	DJ - 12S	12
	DJ - 14S	14
	DJ - 16S	16
	DJ - 20S	20
	DJ - 25S	25
	DJ - 30S	30
	DJ - 38S	38

## General informations

### Features

- **Pressure rating** up to 500bar @ 21°C
- **Temperature rating** from -20°C to 100°C with POM and NBR standard.
- **Conforms to** DIN standard
- **Compact design** with max orifice
- **100% factory tested.**

### Application

- Hydraulic fluids, compressed air, lubricants, and fuel oil systems

### Sour Gas Service

- is provided to meet NACE Standard MR - 01 - 75.

### Testing

- Each valve is tested with nitrogen @ 1000psig(69bar) to max leak rate of 0.1SCCM.
- Hydrostatic shell test is performed at 1.5 times the working pressure as an option.
- Optional tests are available upon request.

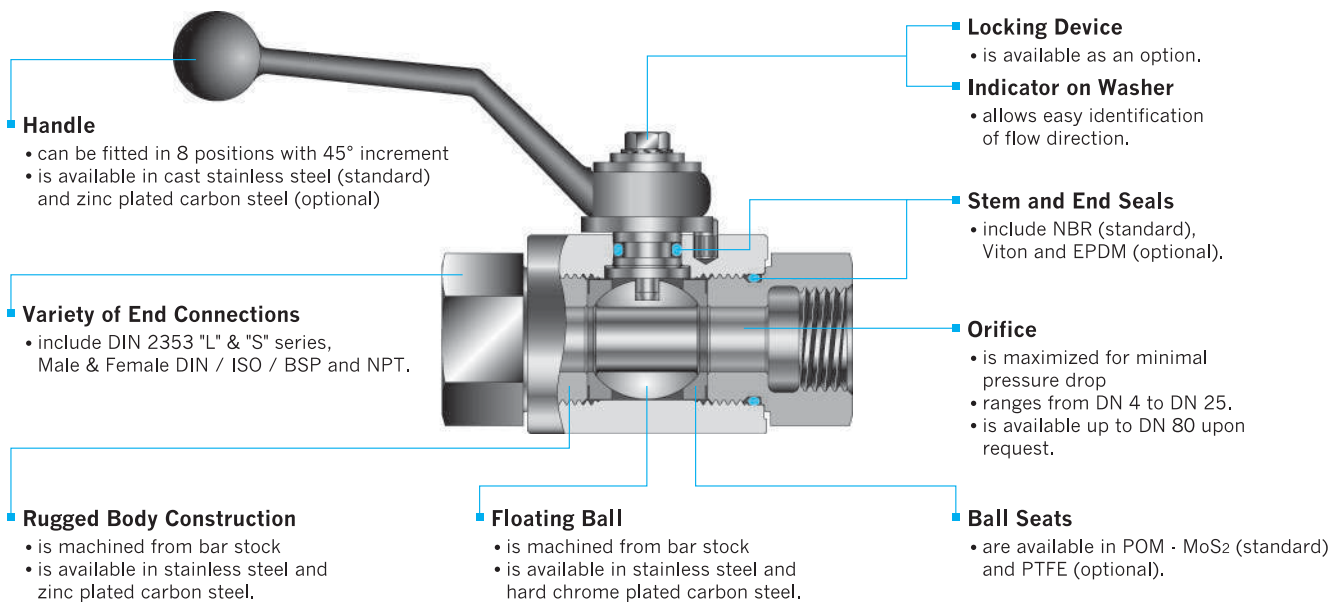

## Technical Data

### Materials of Construction

Description	Specification / Grade			
	Valve Body Materials			
	SS316		Carbon Steel	
	ASTM	DIN	ASTM	DIN
Body				
End Connector	A479 /	17440 /	A108 /	1651 /
Stem	SS316	1.4571	12L14	9SMn28K
Ball	316 Stainless Steel			
Ball Seats*	POM · MoS <sub>2</sub> (Standard)			
Stem & End Seals*	NBR (Standard)			
Handle	SS316		Carbon Steel	
Locking Device	Stainless Steel			

Note : "\*" marked are wetted parts. Lubricant is silicone based.

### Temperature Rating

Seals	
Materials	Temperature Rating
NBR(Buna N)	-23°C to 121°C
Viton	-23°C to 200°C
EPDM	-46°C to 149°C

### Ball Seals

Materials	Temperature Rating
POM · MoS <sub>2</sub>	-30°C to 100°C
PTFE	-54°C to 65°C

## BVDT - L/S

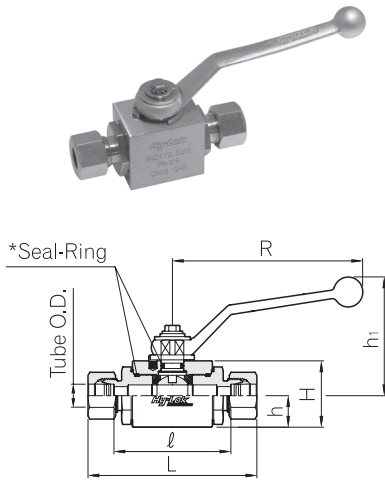

for Light / Heavy Series Tube.

Series	Part No.	Tube O.D.	DN <sup>(1)</sup>	B <sup>(3)</sup>	H	h	h <sub>1</sub>	L	l	R	Weight (kg)	PN(bar)	
												C.Steel	SS316
L	BVDT - 6L	6	4	26	33	13.5	83.0	67	40.0	115	0.4	500	500
	BVDT - 8L	8	6	26	33	13.5	83.0	67	40.0	115	0.4	500	500
	BVDT - 10L	10	6	26	33	13.5	83.0	74	40.0	115	0.5	500	500
	BVDT - 12L	12	10	32	38	17.5	88.5	74	43.0	115	0.6	500	500
	BVDT - 15L	15	13	35	40	19.0	90.0	82	48.0	115	0.7	500	500
	BVDT - 18L	18	13	35	40	19.0	90.0	82	48.0	115	0.8	400	500
	BVDT - 22L	22	20	49	57	24.5	113.0	101	62.0	159	2.1	400	420
	BVDT - 28L	28	25	58	65	29.5	121.0	108	66.2	159	2.3	400	420
	BVDT - 35L	35	25	58	65	29.5	121.0	112	66.2	159	2.3	400	420
	S	BVDT - 8S	8	4	26	33	13.5	83.0	67	40.0	115	0.4	500
BVDT - 10S		10	6	26	33	13.5	83.0	67	40.0	115	0.4	500	500
BVDT - 12S		12	6	32	38	17.5	88.5	74	40.0	115	0.5	500	500
BVDT - 14S		14	10	32	38	17.5	88.5	74	43.0	115	0.6	500	500
BVDT - 16S		16	13	35	40	19.0	90.0	82	48.0	115	0.7	500	500
BVDT - 20S		20	13	35	40	19.0	90.0	82	48.0	115	0.8	400	500
BVDT - 25S		25	20	49	57	24.5	113.0	101	62.0	159	2.1	400	420
BVDT - 30S		30	25	58	65	29.5	121.0	108	66.2	159	2.3	400	420
BVDT - 38S		38	25	58	65	29.5	121.0	112	66.2	159	2.3	315	420

## BVDF - G

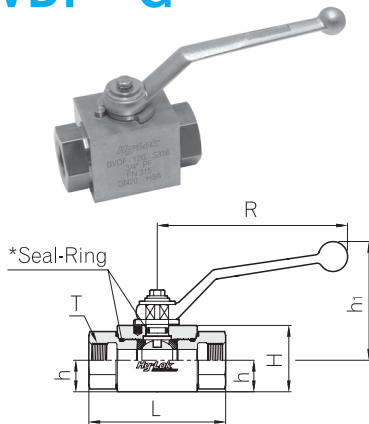

for ISO/BSP Parallel

Part No.	T	DN <sup>(1)</sup>	B <sup>(3)</sup>	H	h	h <sub>1</sub>	L	R	Weight (kg)	PN(bar)	
										C.Steel	SS316
BVDF - 2G	G 1/8	6	26	33	13.5	83.0	68.8	115	0.4	500	500
BVDF - 4G	G 1/4	6	26	33	13.5	83.0	68.8	115	0.4	500	500
BVDF - 6G	G 3/8	10	32	38	17.5	88.5	71.9	115	0.6	500	500
BVDF - 8G	G 1/2	13	35	40	19.0	90.0	82.3	115	0.7	500	500
BVDF - 12G	G 3/4	20	49	57	24.5	113.0	95.4	159	1.6	400	420
BVDF - 16G	G 1	25	58	65	29.5	121.0	112.7	159	2.3	400	420
BVDF - 20G	G 1 1/4	25	58	65	29.5	121.0	120.0	159	2.3	315	420

## BVDF - N

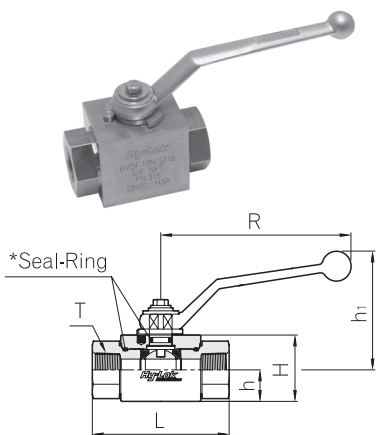

for NPT

Part No.	T	DN <sup>(1)</sup>	B <sup>(3)</sup>	H	h	h <sub>1</sub>	L	R	Weight (kg)	PN(bar)	
										C.Steel	SS316
BVDF - 4N	1/4-18 NPT	6	26	33	13.5	83.0	68.8	115	0.4	500	500
BVDF - 6N	3/8-18 NPT	10	32	38	17.5	83.5	78.0	115	0.6	500	500
BVDF - 8N	1/2-14 NPT	13	35	40	19.0	90.0	104.0	115	0.7	500	500
BVDF - 12N	3/4-14 NPT	20	49	57	24.5	113.0	102.0	159	1.6	400	420
BVDF - 16N	1-11.5 NPT	25	58	65	29.5	121.0	119.0	159	2.3	400	420
BVDF - 20N	1 1/4-11.5 NPT	25	58	65	29.5	121.0	130.0	159	2.3	315	420

**Note :** (1) DN is the max orifice.  
 DN is available up to DN80 upon request.  
 Please consult local authorized Hy-Lok representative  
 (2) Safety factor of PB in bar is 1.5  
 (3) "B" Dimensions are width across flat of body

Dimensions are given for approximate length with tightened nut. All dimensions are in millimeters for reference only, subject to change.  
 \*The standard Seal-Ring material is FPM(e.g. Viton®) however NBR(e.g. perbunan®) is also available on request (See Page 3).

## General informations for Non-Return Valves

### Application

For hydraulic fluid and compressed air.

Please contact our technical support team for doubtful conditions or the use of special fluids.

### Design

Hy-Lok Corp. non return valves are leak-free by elastic materials (e.g. Viton®), and internal parts provide optimal flow conditions for the fluids.

### Opening Pressure

The non return valves are tested at the factory with opening pressure of approx.1 bar. Other opening pressures, ranging from 0.5 to 3 bar, are also available on request.

### Materials

Stainless steel 316, carbon steel or brass is available for standard material on request.

The standard Seal-Rings is FPM (e.g. Viton®) however other materials are also available on request.

## Non Return Valve DCVU

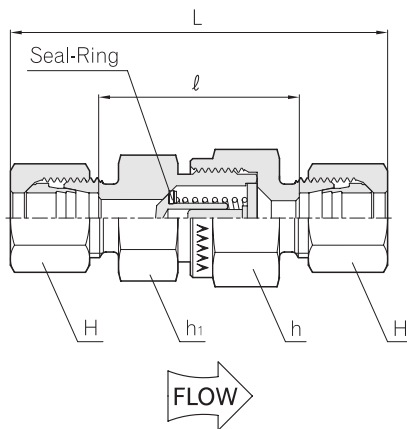

Series	Part No.	Tube O.D.	H	h	h <sub>1</sub>	L	l	PN(bar)	
								C.Steel	SS316
L	DCVU - 06L	6	14	17	17	58.0	29.0	400	250
	DCVU - 08L	8	17	19	19	59.0	30.0	400	250
	DCVU - 10L	10	19	24	22	69.5	40.5	400	250
	DCVU - 12L	12	22	30	27	72.5	43.5	400	250
	DCVU - 15L	15	27	32	27	77.5	47.5	400	250
	DCVU - 18L	18	32	36	36	83.5	51.5	400	160
	DCVU - 22L	22	36	46	41	93.5	61.5	250	160
	DCVU - 28L	28	41	55	50	102.5	69.5	250	100
	DCVU - 35L	35	50	60	60	117.5	74.5	250	100
	DCVU - 42L	42	60	70	65	119.0	74.0	250	100
S	DCVU - 06S	6	17	19	19	63.5	34.5	420	400
	DCVU - 08S	8	19	19	19	63.5	34.5	420	400
	DCVU - 10S	10	22	24	22	72.5	40.5	420	400
	DCVU - 12S	12	24	27	24	74.5	42.5	420	400
	DCVU - 14S	14	27	32	27	82.5	47.5	420	315
	DCVU - 16S	16	30	36	32	86.5	50.5	420	315
	DCVU - 20S	20	36	46	41	97.5	54.5	420	250
	DCVU - 25S	25	46	50	46	106.5	58.5	420	250
	DCVU - 30S	30	50	60	60	122.5	69.5	250	250
	DCVU - 38S	38	60	70	65	136.5	75.5	250	250

Dimensions are given for approximate length with tightened nut. All dimensions are in millimeters for reference only, subject to change.

\* The standard Seal-Ring material is FPM(e.g. Viton®) however NBR(e.g. perbunan®) is also available on request (See Page 3).

Non Return Valve  
**DCV GED-L/S**  
**MED-L/S**

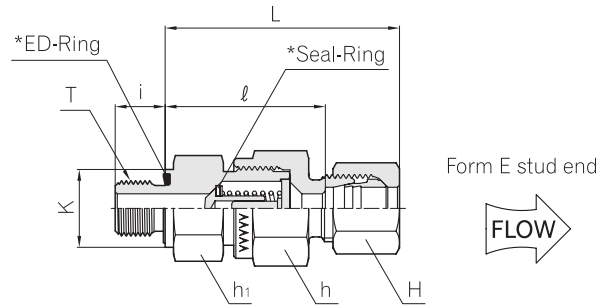

for ISO/BSP Parallel

Series	Part No.	Tube O.D.	H	h	h <sub>1</sub>	K	L	l	i	T	PN(bar)	
											C.Steel	SS316
L	DCV01GED-06L	6	14	17	17	14	42.5	28.0	8	G 1/8	400	250
	DCV02GED-08L	8	17	19	19	19	44.5	30.0	12	G 1/4	400	250
	DCV02GED-10L	10	19	24	22	19	53.0	38.5	12	G 1/4	400	250
	DCV03GED-12L	12	22	30	27	22	57.0	42.5	12	G 3/8	400	250
	DCV04GED-15L	15	27	32	27	27	60.5	45.5	14	G 1/2	400	250
	DCV04GED-18L	18	32	36	36	27	66.0	50.0	14	G 1/2	400	160
	DCV06GED-22L	22	36	46	41	32	71.0	53.0	16	G 3/4	250	160
	DCV08GED-28L	28	41	55	50	40	79.5	63.0	18	G 1	250	100
	DCV10GED-35L	35	50	60	60	50	90.5	69.0	20	G 1 1/4	250	100
DCV12GED-42L	42	60	70	65	55	91.0	68.5	22	G 1 1/2	250	100	
S	DCV02GED-06S	6	17	19	19	19	46.0	31.5	12	G 1/4	420	400
	DCV02GED-08S	8	19	19	19	19	46.0	31.5	12	G 1/4	420	400
	DCV03GED-10S	10	22	24	22	22	54.0	38.0	12	G 3/8	420	400
	DCV03GED-12S	12	24	27	24	22	57.0	41.0	12	G 3/8	420	400
	DCV04GED-14S	14	27	32	27	27	62.0	44.5	14	G 1/2	420	315
	DCV04GED-16S	16	30	36	32	27	66.0	48.0	14	G 1/2	420	315
	DCV06GED-20S	20	36	46	41	32	73.5	52.0	16	G 3/4	420	250
	DCV08GED-25S	25	46	50	46	40	78.5	54.5	18	G 1	420	250
	DCV10GED-30S	30	50	60	60	50	90.5	64.0	20	G 1 1/4	250	250
DCV12GED-38S	38	60	70	65	55	100.0	69.5	22	G 1 1/2	250	250	

for Metric Parallel

Series	Part No.	Tube O.D.	H	h	h <sub>1</sub>	K	L	l	i	T	PN(bar)	
											C.Steel	SS316
L	DCVM10ED-06L	6	14	17	17	14	42.5	28.0	8	M10 x 1.0	400	250
	DCVM12ED-08L	8	17	19	19	17	43.5	30.0	12	M12 x 1.5	400	250
	DCVM14ED-10L	10	19	24	22	19	53.0	38.5	12	M14 x 1.5	400	250
	DCVM16ED-12L	12	22	30	27	22	57.0	42.5	12	M16 x 1.5	400	250
	DCVM18ED-15L	15	27	32	27	24	60.5	45.5	12	M18 x 1.5	400	250
	DCVM22ED-18L	18	32	36	36	27	66.0	50.0	14	M22 x 1.5	400	160
	DCVM26ED-22L	22	36	46	41	32	71.0	55.0	16	M26 x 1.5	250	160
	DCVM33ED-28L	28	41	55	50	40	79.5	63.0	18	M33 x 2.0	250	100
	DCVM42ED-35L	35	50	60	60	50	90.5	69.0	20	M42 x 2.0	250	100
DCVM48ED-42L	42	60	70	65	55	91.0	67.5	22	M48 x 2.0	250	100	
S	DCVM12ED-06S	6	17	19	19	17	46.0	31.5	12	M12 x 1.5	420	400
	DCVM14ED-08S	8	19	19	19	19	46.0	31.5	12	M14 x 1.5	420	400
	DCVM16ED-10S	10	22	24	22	22	54.0	38.0	12	M16 x 1.5	420	400
	DCVM18ED-12S	12	24	27	24	24	57.0	41.0	12	M18 x 1.5	420	400
	DCVM20ED-14S	14	27	32	27	26	62.0	44.5	14	M20 x 1.5	420	315
	DCVM22ED-16S	16	30	36	32	27	66.0	48.0	14	M22 x 1.5	420	315
	DCVM27ED-20S	20	36	46	41	32	73.5	52.0	16	M27 x 2.0	420	250
	DCVM33ED-25S	25	46	50	46	40	78.5	54.5	18	M33 x 2.0	420	250
	DCVM42ED-30S	30	50	60	60	50	90.5	64.0	20	M42 x 2.0	250	250
DCVM48ED-38S	38	60	70	65	55	100.0	69.5	22	M48 x 2.0	250	250	

Dimensions are given for approximate length with tightened nut, All dimensions are in millimeters for reference only, subject to change.

\* The standard Seal-Ring material is FPM(e.g. Viton®) however NBR(e.g. perbunan®) is also available on request (See Page 3).

\* The standard ED-Ring material is NBR(e.g. perbunan®) however FPM(e.g. Viton®) is also available on Request (See Page3).

## Non-Return Valves

### Non Return Valve DCV L/S-GED L/S-MED

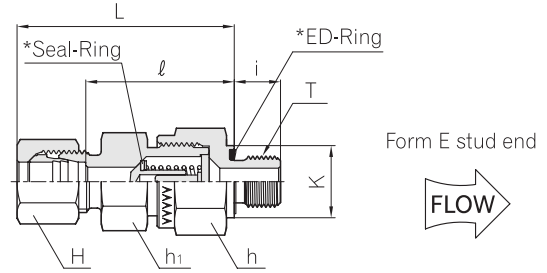

for ISO/BSP Parallel

Series	Part No.	Tube O.D.	H	h	h <sub>1</sub>	K	L	l	i	T	PN(bar)	
											C.Steel	SS316
L	DCV06L-01GED	6	14	17	17	14	41.0	26.5	8	G 1/8	400	250
	DCV08L-02GED	8	17	19	19	19	43.0	28.5	12	G 1/4	400	250
	DCV10L-02GED	10	19	24	22	19	53.0	38.5	12	G 1/4	400	250
	DCV12L-03GED	12	22	30	27	22	55.0	40.5	12	G 3/8	400	250
	DCV15L-04GED	15	27	32	27	27	57.5	42.5	14	G 1/2	400	250
	DCV18L-04GED	18	32	36	36	27	64.0	48.0	14	G 1/2	400	160
	DCV22L-06GED	22	36	46	41	32	72.0	56.0	16	G 3/4	250	160
	DCV28L-08GED	28	41	55	50	40	80.5	64.0	18	G 1	250	100
	DCV35L-10GED	35	50	60	60	50	91.5	70.0	20	G 1 1/4	250	100
DCV42L-12GED	42	60	70	65	55	93.0	70.5	22	G 1 1/2	250	100	
S	DCV06S-02GED	6	17	19	19	19	46.0	31.5	12	G 1/4	420	400
	DCV08S-02GED	8	19	19	19	19	46.0	31.5	12	G 1/4	420	400
	DCV10S-03GED	10	22	24	22	22	54.0	38.0	12	G 3/8	420	400
	DCV12S-03GED	12	24	27	24	22	57.0	41.0	12	G 3/8	420	400
	DCV14S-04GED	14	27	32	27	27	61.0	43.5	14	G 1/2	420	315
	DCV16S-04GED	16	30	36	32	27	64.0	46.0	14	G 1/2	420	315
	DCV20S-06GED	20	36	46	41	32	71.5	50.0	16	G 3/4	420	250
	DCV25S-08GED	25	46	50	46	40	78.5	54.5	18	G 1	420	250
	DCV30S-10GED	30	50	60	60	50	90.5	64.0	20	G 1 1/4	250	250
DCV38S-12GED	38	60	70	65	55	102.0	71.5	22	G 1 1/2	250	250	

for Metric Parallel

Series	Part No.	Tube O.D.	H	h	h <sub>1</sub>	K	L	l	i	T	PN(bar)	
											C.Steel	SS316
L	DCV06L-M10ED	6	14	17	17	14	41.0	26.5	8	M10 x 1.0	400	250
	DCV08L-M12ED	8	17	19	19	17	43.0	28.5	12	M12 x 1.5	400	250
	DCV10L-M14ED	10	19	24	22	19	53.0	38.5	12	M14 x 1.5	400	250
	DCV12L-M16ED	12	22	30	27	22	55.0	40.5	12	M16 x 1.5	400	250
	DCV15L-M18ED	15	27	32	27	24	57.5	42.5	12	M18 x 1.5	400	250
	DCV18L-M22ED	18	32	36	36	27	64.0	48.0	14	M22 x 1.5	400	160
	DCV22L-M26ED	22	36	46	41	32	72.0	56.0	16	M26 x 1.5	250	160
	DCV28L-M33ED	28	41	55	50	40	80.5	64.0	18	M33 x 2.0	250	100
	DCV35L-M42ED	35	50	60	60	50	91.5	70.0	20	M42 x 2.0	250	100
DCV42L-M48ED	42	60	70	65	55	93.0	70.5	22	M48 x 2.0	250	100	
S	DCV06S-M12ED	6	17	19	19	17	46.0	31.5	12	M12 x 1.5	420	400
	DCV08S-M14ED	8	19	19	19	19	46.0	31.5	12	M14 x 1.5	420	400
	DCV10S-M16ED	10	22	24	22	22	54.0	38.0	12	M16 x 1.5	420	400
	DCV12S-M18ED	12	24	27	24	24	57.0	41.0	12	M18 x 1.5	420	400
	DCV14S-M20ED	14	27	32	27	26	61.0	43.5	14	M20 x 1.5	420	315
	DCV16S-M22ED	16	30	36	32	27	64.0	46.0	14	M22 x 1.5	420	315
	DCV20S-M27ED	20	36	46	41	32	71.5	50.0	16	M27 x 2.0	420	250
	DCV25S-M33ED	25	46	50	46	40	78.5	54.5	18	M33 x 2.0	420	250
	DCV30S-M42ED	30	50	60	60	50	90.5	64.0	20	M42 x 2.0	250	250
DCV38S-M48ED	38	60	70	65	55	102.0	71.5	22	M48 x 2.0	250	250	

Dimensions are given for approximate length with tightened nut. All dimensions are in millimeters for reference only, subject to change.

\* The standard Seal-Ring material is FPM(e.g. Viton®) however NBR(e.g. perbunan®) is also available on request (See Page 3).

\* The standard ED-Ring material is NBR(e.g. perbunan®) however FPM(e.g. Viton®) is also available on Request (See Page3).

## General Information

EZY-MAT II, Hy-Lok's Auto Hydraulic Pre-swaging Machine, designed for use to all DIN 2353 tube fittings ranging 6-42mm. The standard version is for 220V. 110V version is also available on request.

## Swaging Process

Sleeve, nut and tube are properly pre-assembled. Tube end shall reach to the swaging cone shoulder. Tapered face of sleeve shall contact swaging cone. Nut shall be fixed to swaging cone. Swaging process shall be performed by pressing "start button". The piston with the swaging cone shall be advanced. Once the set pressure has been reached the swaging process shall be concluded. The piston with the swaging cone automatically returns to its initial position. Now, pre-swaging is completed.

## Technical Data

- 220V version
  - Hydraulic pump : 0.35kW · 2.0l/min.
  - Operating pressure : 0~600bar.
  - Connection : 220V / 1~50 / 60Hz / 2.5A
  - Dimension : 400 X 400 X 230mm
  - Weight : 30kg
  - 110V version is also available upon request



## Ordering Information

- Contact our technical support team or service representatives for your local area.

## How to Set-up EZY-MAT II

1. Insert the changeable fixture into the tool mounting.
2. Select the swaging cone and locating plate in accordance with the tube size and type.
3. Attach the swaging cone to the mounting tool. Place the locating plate at the changeable fixture.

## How to Prepare Tube

4. Check if tube O.D, wall thickness, circularity, hardness and their tolerances are within specifications for your application.
5. Make a square cut.
6. Remove burrs from inner and outer edges of tube.

## How to Make Pre-swage

7. Set up the swaging pressure for each size shown in Table 1 which is for carbon steel only.
8. Lubricate the sleeve, nut and swaging cone.
9. Slide the nut and sleeve onto the locating plate, so that the nut and sleeve are placed between the locating plate and the swaging cone.
10. Hold the tube and press the "start" switch. pre-swaging is now completed.
11. The pre-swaged tube may be removed from the locating plate. The sleeve has cut into the tube leaving a visible raised collar(check!).
12. Lubricate the thread and cone of the fitting. Insert the previously pre-swaged tube into the corresponding tube fitting. Tighten the nut with approximately 1/2 turn from the point where application of increased effort is required.
13. For continuous operation, go to step 2.

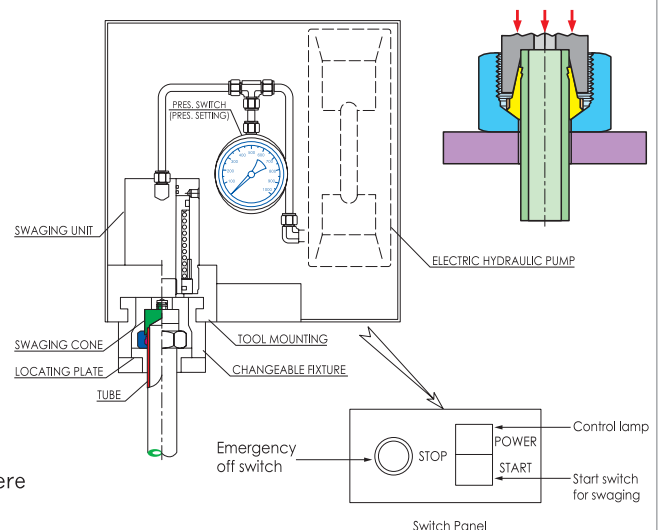

# Pre - Swaging Machine

## Important!

1. The pressure must be set according to the data stated on the machine. Incorrect pressure setting leads to incomplete swaging.
2. Long tube lengths must be used during the swaging process.
3. Dirt, chips and others can interfere with proper swaging process.
4. When assembling Tube fitting :  
Alignment of fitting and tube shall be done before tightening the nut.  
Nut should be tightened on the fitting body without resistance.
5. For another tube material, please operate the unit after adjustment of the swaging pressure on reference to the "⚠ CAUTION".  
Different characteristics of materials may require different swaging pressure.

Table 1.

Tube O.D (mm)	Pressure (bar)
6	20
8	30
10	35
12	45
14	55
15	55
16	65
18	65
20	80
22	80
25	110
28	110
30	165
35	155
38	215
42	195

### ⚠ CAUTION

Check penetration of cutting edge.  
A visible collar should fill out the space in front of the cutting ring face.  
Cutting ring may be turned on the tube but should not be moved axially.

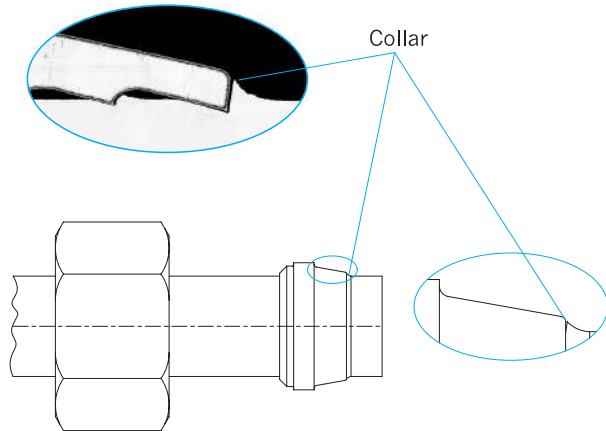



This assembly instruction related to DIN 2353 fittings shows suitable make-up for fittings into seamless pipe in accordance with DIN 3859.

### 3 Methods might be used for assembly.

Assembly by direct fitting body.

Assembly by using pre-assembly tool.

Assembly of standpipe & cone fitting with O-ring

***In order to ensure positive assembly, stainless steel fittings should be always pre-assembled by an oiled pre-assembly tool.***

### ■ Assembly of cutting ring fittings in direct fitting body.

1.0 Saw the tube at right angle. An angular offset of  $1/2^\circ$  in relation to the tube axis is permissible.

1.1 After clean, lightly deburr the tube ends on the inside and outside of the edge.

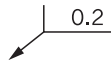

1.2 Use of a tube cutter may cause formation of considerable burrs and an angular cut. Preferred method is to use a sawing machine or a device instead.

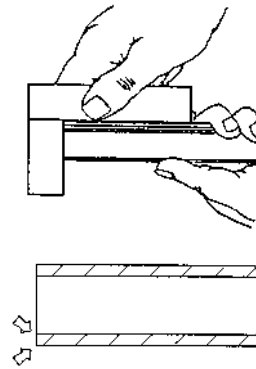

2.0 Lubricate thread and inside of the fitting body, cutting ring and thread of the nut.

Do not use grease.

2.1 Place the nut and the cutting ring on tube shown as the picture.

Ensure the cutting ring and the nut face the right way.

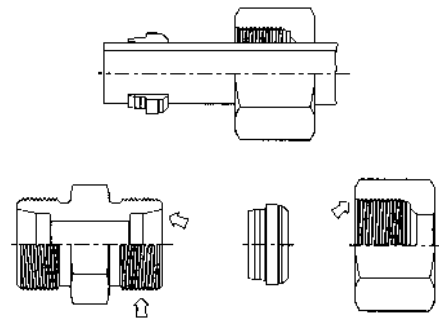

3.0 Insert the tube into the fitting body, up to the tube abutment, then hand-tighten the nut.

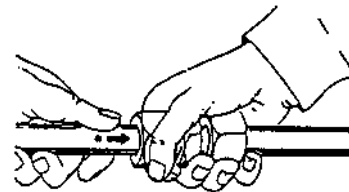

4.0 Make sure the nut is in hand tight position, then tighten the 1 1/2 turns with a wrench during holding fitting body with a second wrench. (Never turn the fitting body, hold the body and turn the nut)

#### Caution!

*Any deviating of tightening turns reduces the nominal pressure and the service life of the fitting, and may cause leakages or slip of the tube.*

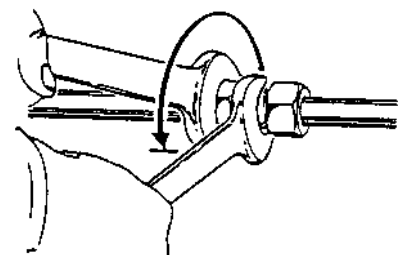

## 24° Tube Fittings-DIN 2353 & ISO 8434-1

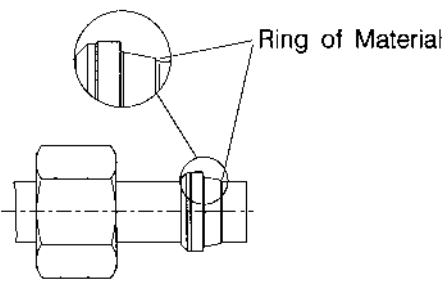
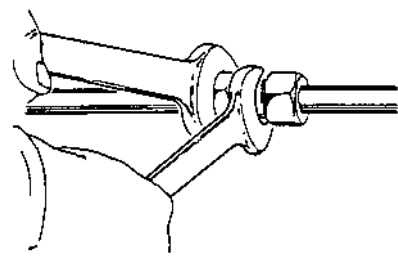
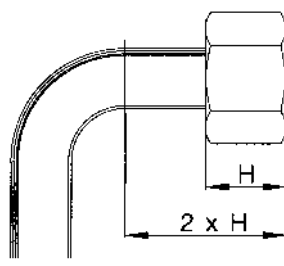
<p>5.0 Check penetration of cutting edge.          A visible ring of material should fill out the space in front of cutting ring face.          Cutting ring may be turned on tube, but should not be moved axially.</p>	
<p>6.0 In case that the fitting is disassembled, the nut must be retightened firmly using the same torque as required for final assembly.</p>	
<p>7.0 Minimum length of a straight tube must be at least twice (2xH) the nut Height (H).</p>	

### ■ Assembly of cutting ring fittings in pre-assembly tool.

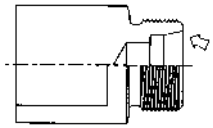
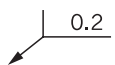
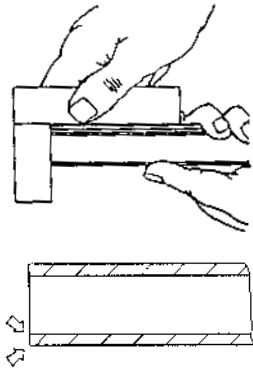
<p>1.0 In order to ensure positive assembly, Hy-Lok Corp. DIN fittings should be always pre-assembled by an oiled pre-assembly tool.          For direct assembly, torque-controlled assembly or mechanical pre-assembly is also possible.</p>	
<p>2.0 Saw the tube at right angle. An angular offset of 1/2° in relation to the tube axis is permissible.          2.1 After clean, lightly deburr the tube ends at the inside and outside edge.          2.2 Use of tube cutter may cause formation of considerable burrs and an angular cut.          Preferred method is to use a sawing machine instead.</p> <p style="margin-left: 100px;">  </p>	

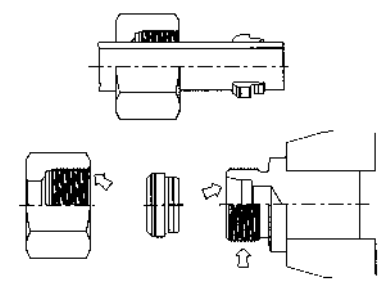
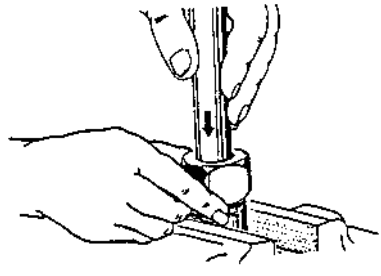
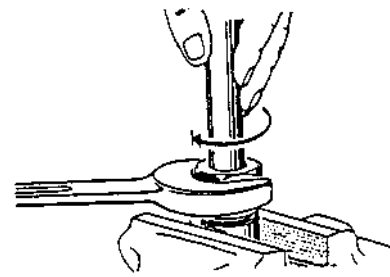
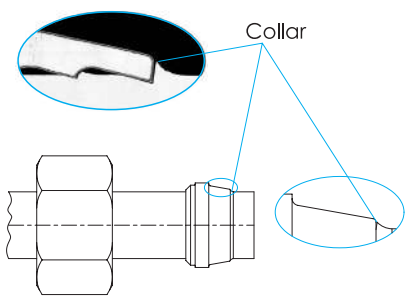
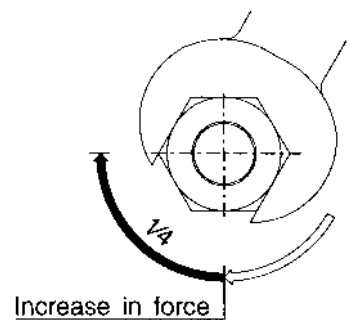
<p>3.0 Lubricate the thread, inside of the fitting body, the cutting ring and also the thread of the nut. Do not grease.</p> <p>3.1 Place the nut and the cutting ring on tube shown as the picture. Ensure the cutting ring and the nut face the right way.</p>	
<p>4.0 Insert the tube into the fitting body, up to the tube abutment, then hand-tighten the nut.</p>	
<p>5.0 Make sure the nut is in hand tight position, then tighten 1 1/4 turns with a wrench during holding fitting body with a second wrench. (Never turn the fitting body, hold the body and turn the nut)</p> <p><b>Caution!</b> <i>Application of deviating of tightening turns reduces the nominal pressure rating and the life of the fitting, and may cause leakages or slip of the tube.</i></p>	
<p>6.0 Check penetration of cutting edge. A visible ring of material should fill out the space in front of cutting ring face. The cutting ring may be turned on the tube but should not be moved axially.</p>	
<p>7.0 Tighten the nut by hand until application of increased effort is required. Beyond this point, tighten the nut by 1/4 turn with a wrench for final assembly.</p> <p>7.1 With unfavourable mounting conditions and great tube dimensions, final assembly must be completed with the fitting body in a vice.</p> <p><b>Caution!</b> <i>Any deviating of tightening turns reduces the nominal pressure rating and the life of the fitting which cause leakage or slip of the tube.</i></p>	

## 24° Tube Fittings-DIN 2353 & ISO 8434-1

8.0 In case that the fitting is disassembled, the nut must be retightened firmly using the same torque as required for final assembly.

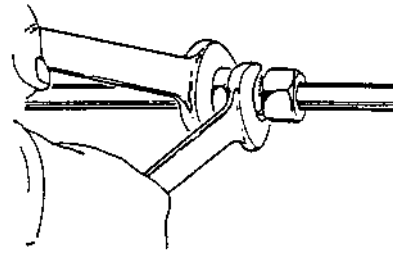

9.0 Minimum length of a straight tube must be at least twice (2xH) the nut height (H).

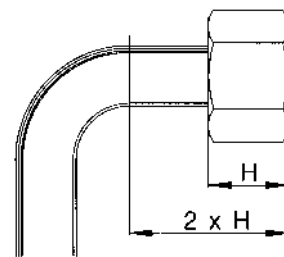

### ■ Assembly instruction for standpipe & cone fitting with O-Ring.

1.0 Tighten the nut 1/4 turn with a wrench beyond application of increased effort is required.

1.1 In difficult mounting situation on large tube sizes, final assembly must be completed in vice with the fitting body.

**Caution!**

*Any deviating of tightening turns reduces the nominal pressure and the service life of the fitting, and may cause leakages or slip of the fitting.*

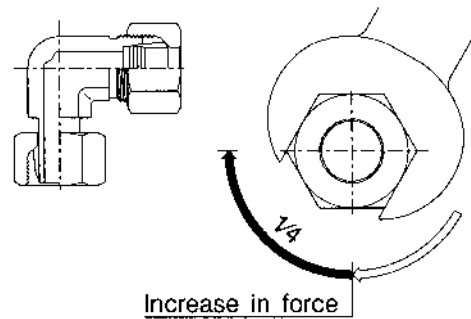

2.0 Oil O-ring.

Tighten the nut 1/4 turn with a wrench beyond application of increased effort is required.

Hold fitting body firmly by means of wrench.

2.1 In difficult mounting situation on large tube sizes, final assembly must be completed in vice with the fitting body.

**Caution!**

*Any deviating of tightening turns reduces the nominal pressure and the service life of the fitting, and may cause leakages or slip of the fitting.*

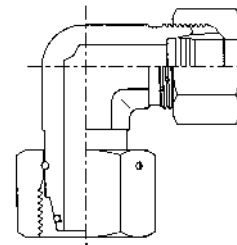

## HyQ Assembly Instruction [Direct Assembly]

### ■ Instruction for Smaller size assembly

No effect on Series Assembly

Preliminary assembly of tube size 30, 35, 38 and 42mm shall be performed in vice.

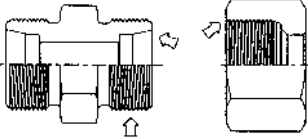
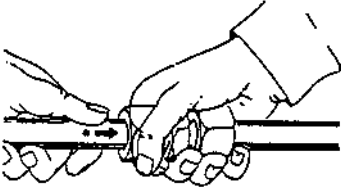
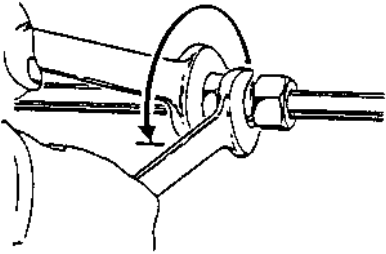
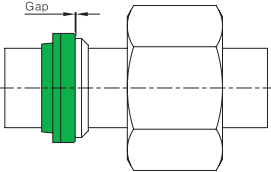
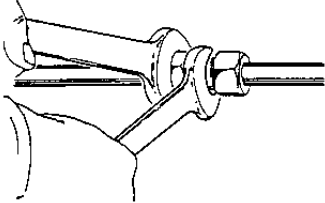
<p>1.0 The thread of fitting shall be lubricated.</p>	
<p>2.0 Certainly push the tube on the inner part. Loosen the nut in order to easily insert the tube.</p>	
<p>3.0 Tighten the nut until the resistance is felt (about 1 turn to 1 1/2 turn) Spanner may be better to use in over 20mm O.D]</p>	
<p>4.0 Assembly Verification It Shall be no space between sealing ring and retaining ring. It may allow the tolerance of 0.2mm.</p>	
<p>5.0 Gap not Closed All components including tube shall be verified regarding the space.</p>	
<p>6.0 Fitting shall be assembled until securely tighten with wrench (without spanner) The body shall be surely fixed.</p>	
<p>7.0 Securely tighten the fitting by minimum 1/6 turn (max. 1/4)</p>	

**■ Assembly in vice**

Reliable method

This method is economical for small amount of assembly.

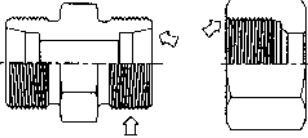
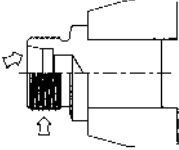
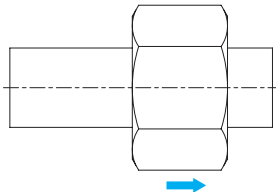
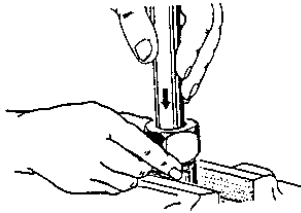
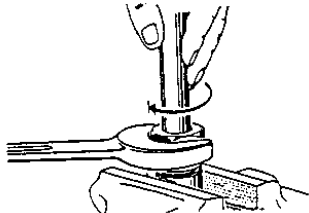
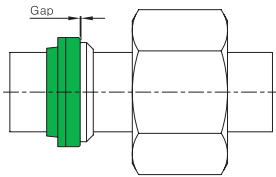
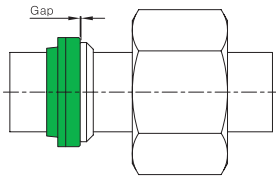
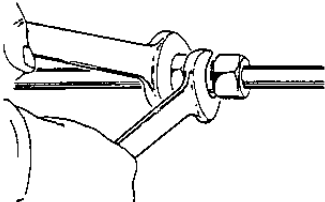
<p>1.0 The thread of fitting shall be lubricated.</p>	
<p>2.0 Using "DJ" which is preliminary mounting tool. It suggests that the body shall be mounted at once to prevent the leak, and all components shall be included.</p>	
<p>3.0 Push the nut to the end of tube. Benefits: Easy to insert the tube, especially for a large dimension.</p>	
<p>4.0 Certainly push the tube on the inner part. Tighten the nut with hands.</p>	
<p>5.0 Tighten the nut until the resistance is felt (about 1 turn to 1 1/2 turn) Spanner may be better to use in over 20mm O.D</p>	
<p>6.0 Assembly Verification It Shall be no space between sealing ring and retaining ring. It may allow the tolerance of 0.2mm.</p>	
<p>7.0 Gap not Closed Repeated assembly by increased torque, and verify the gap.</p>	
<p>8.0 Fitting shall be assembled until securely tighten with wrench (without spanner) The body shall be surely fixed.</p>	



Distributed by :